

Roca

CIRCULAR BATH

A248204	A248208
A248205	A248209
A248206	A248210
A248207	A248211

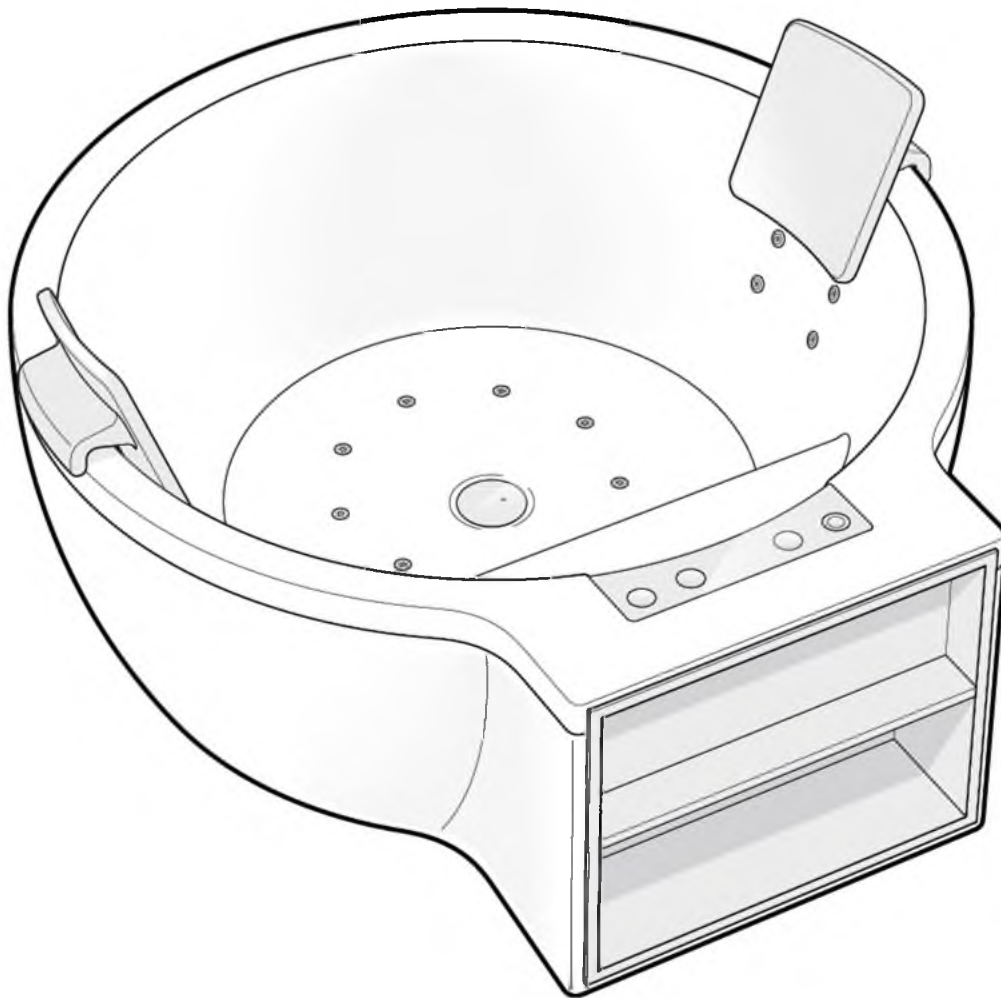

ES Enhorabuena y gracias por la adquisición de este producto, el cual ha sido diseñado, fabricado y verificado por nuestro personal técnico. Asimismo si ha adquirido faldón, con él encontrará las instrucciones específicas para su instalación.

EFFECTOS DEL MASAJE

La acción de las burbujas de aire sobre el cuerpo ha demostrado ser muy beneficiosa para la salud. Pueden mencionarse especialmente los siguientes efectos:

- Estimulo y mejora de la higiene de la superficie cutánea y de la circulación cardiovascular.
- Mejora general de la circulación capilar y linfática.
- Agilización muscular y oxigenación de la piel.
- Resulta especialmente indicado en caso de dolores musculares, lumbago, artritis, recuperaciones post-operatorias, stress y estados de fatiga en general.

PRECAUCIONES

- Este aparato no está destinado para ser usado por personas (incluidos niños) cuyas capacidades físicas, sensoriales o mentales estén reducidas, o carezcan de experiencia o conocimientos, salvo si han tenido supervisión o instrucciones relativas al uso del aparato por una persona responsable de su seguridad.
- La limpieza y mantenimiento a realizar por el usuario no deben realizarlo niños sin supervisión. El aparato se debe limpiar adecuadamente según el apartado de limpieza del presente manual.
- Los niños deberían ser supervisados para asegurar que no juegan con el aparato.
- A pesar de los efectos terapéuticos preventivos y relajantes del hidromasaje, es importante señalar que en caso de afecciones agudas, cardiopatías descompensadas, hipertensiones graves o cierto tipo de enfermedades infecciosas, así como para determinado tipo de personas (niños, ancianos, embarazadas), deben tenerse en cuenta unas condiciones especiales de duración, temperatura y frecuencia. En estas situaciones es recomendable la consulta previa al médico.
- Se recomienda no tomar un baño después de beber alcohol ni después de comer.
- Utilice únicamente agua de la red doméstica debidamente tratada y desinfectada.
- En caso de que la dureza del agua de la instalación sea muy elevada, para tener la seguridad de que el equipo de hidromasaje funcione correctamente conviene instalar un descalcificador.
- No utilizar un baño de espuma con el hidromasaje ya que la cantidad de espuma producida podría sobresalir de la bañera.

INSTALACIÓN Y MANTENIMIENTO

- Para garantizar la seguridad del uso del aparato, este producto debe ser instalado y reparado por personal cualificado, capaz de demostrar a las autoridades competentes sus conocimientos y su competencia en lo que respecta a la aplicación de los requisitos reglamentarios nacionales relativos a la seguridad, aplicables a la instalación eléctrica y a la fontanería.

EN We congratulate you and thank you for purchasing this Roca product, which has been designed, manufactured and checked by our technical staff. Likewise, if you purchased the panel, it will include specific instructions for installing it.

EFFECTS OF MASSAGE

The action of the air bubbles on the body has been proven to be highly beneficial for the health. The following effects are particularly worth mentioning:

- Stimulates and improves skin hygiene and cardiovascular circulation.
- Generally improves capillary and lymph circulation.
- Tones the muscles and oxygenates the skin.
- Particularly indicated in cases of muscle pain, lumbago, arthritis, post-operative convalescence, stress and fatigue in general.

PRECAUTIONS

- This device is not intended to be used by people (including children) whose physical, sensory or mental capabilities are reduced, or no experience or knowledge, unless they have supervision or instructions concerning the use of the apparatus by a person responsible for security.
- Cleaning and maintenance of this device must not be done by children without supervision.
- Children should be supervised to ensure they do not play with the device.
- In spite of the preventive and relaxing therapeutic effects of hydro-massage, it is important to note that in the case of acute conditions, uncompensated heart disease, serious hypertension or certain infectious diseases, and in the case of certain groups (children, the elderly, and pregnant women), certain special conditions regarding bath duration, temperature and frequency must be borne in mind. In these situations it is advisable to consult your doctor first.
- It is recommended not to take a bath directly after drinking alcohol or having a meal.
- Use only water from your home network properly treated and disinfected.
- If the water hardness of the installation is very high, it is advisable to install a water softener to guarantee that the whirlpool equipment is working properly.
- Do not use foam-bath products with the whirlpool since the amount of foam produced could lead to overflows.

INSTALLATION AND MAINTENANCE

- To guarantee the safety of use of this product, it should only be installed and repaired by qualified installers, who can demonstrate to the appropriate authorities awareness and competence in the application of National Regulatory requirements for safety, i.e. electrical and water supply/disposal.



* Sólo modelos "Hidro" / "Hidro" models only

** Sólo modelos "Corner" / "Corner" models only

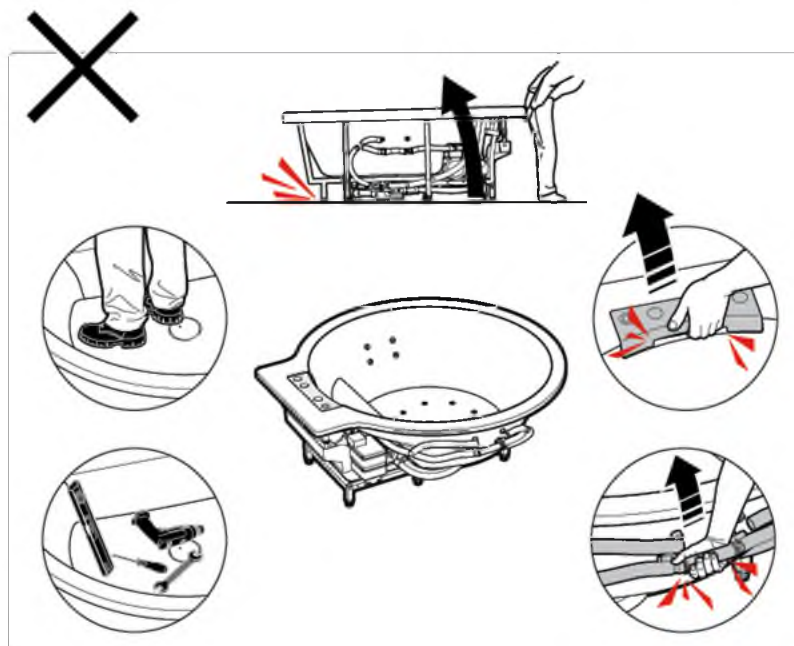
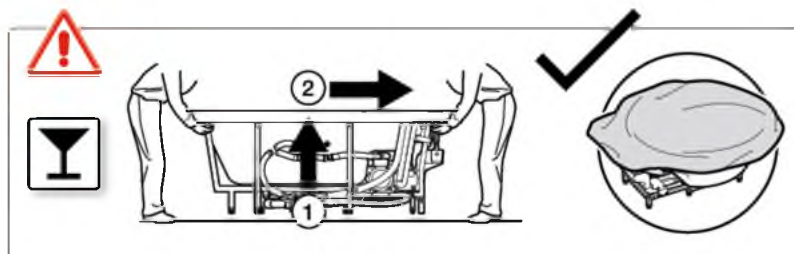
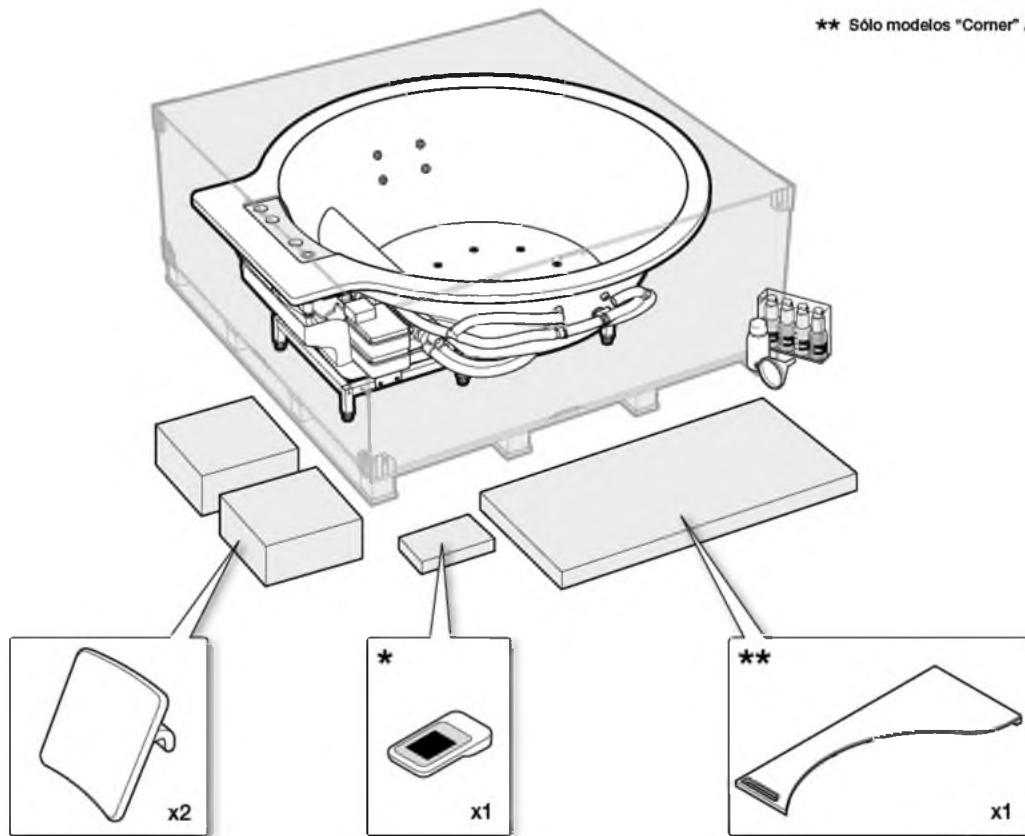

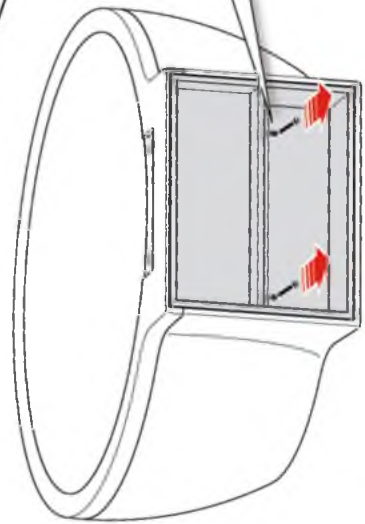

1

1

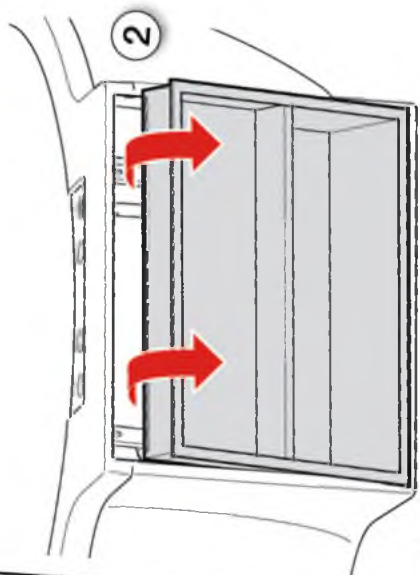

2

2

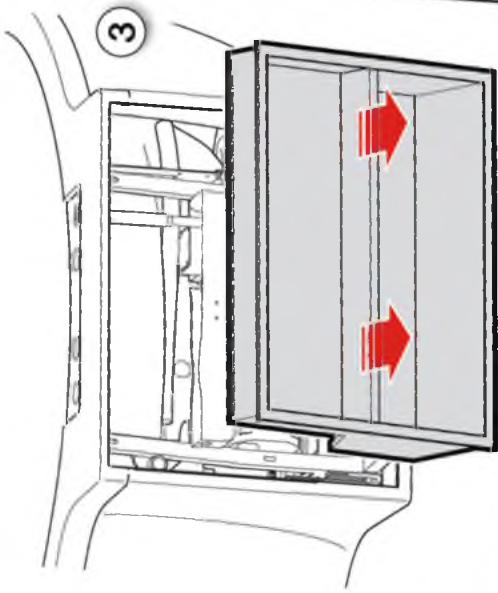

3

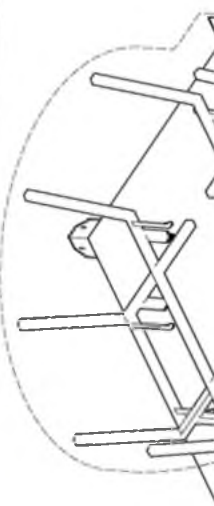
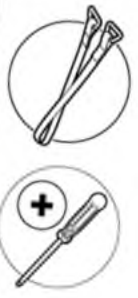

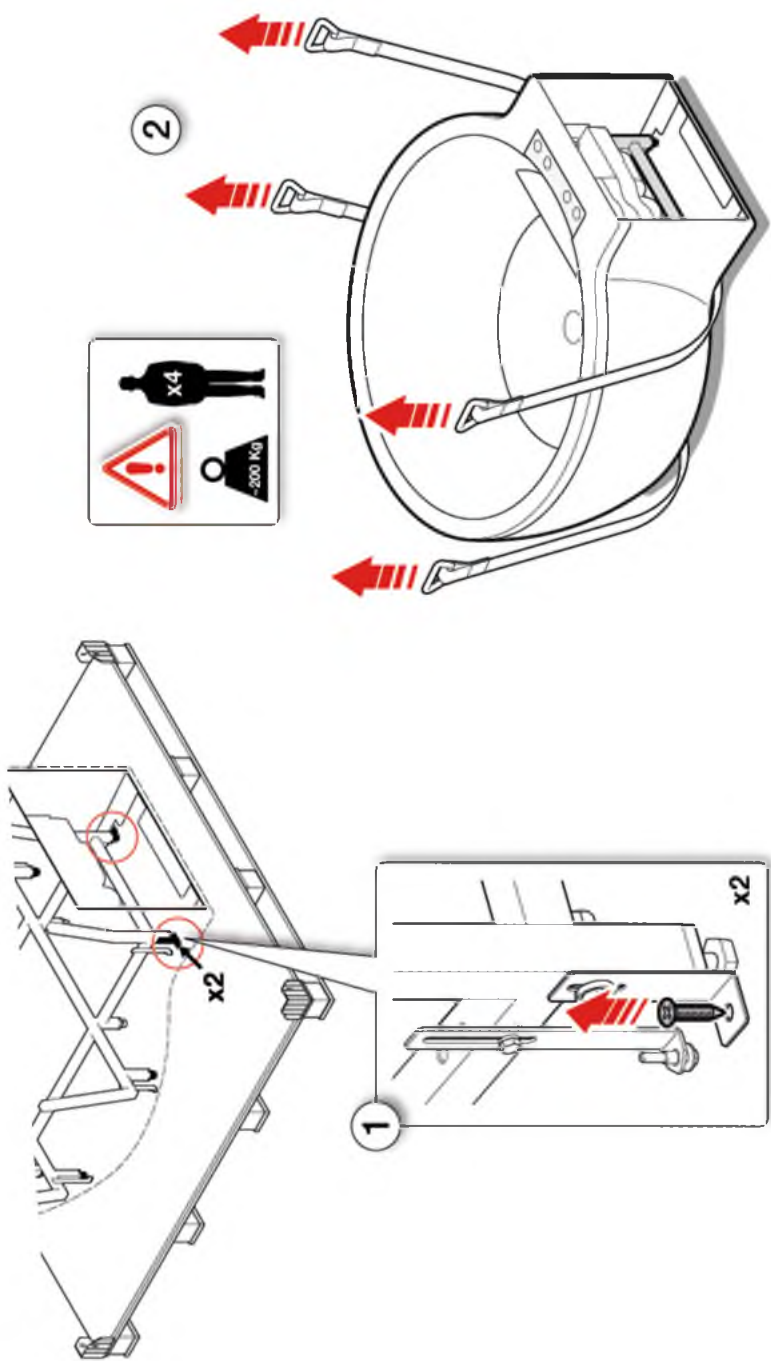

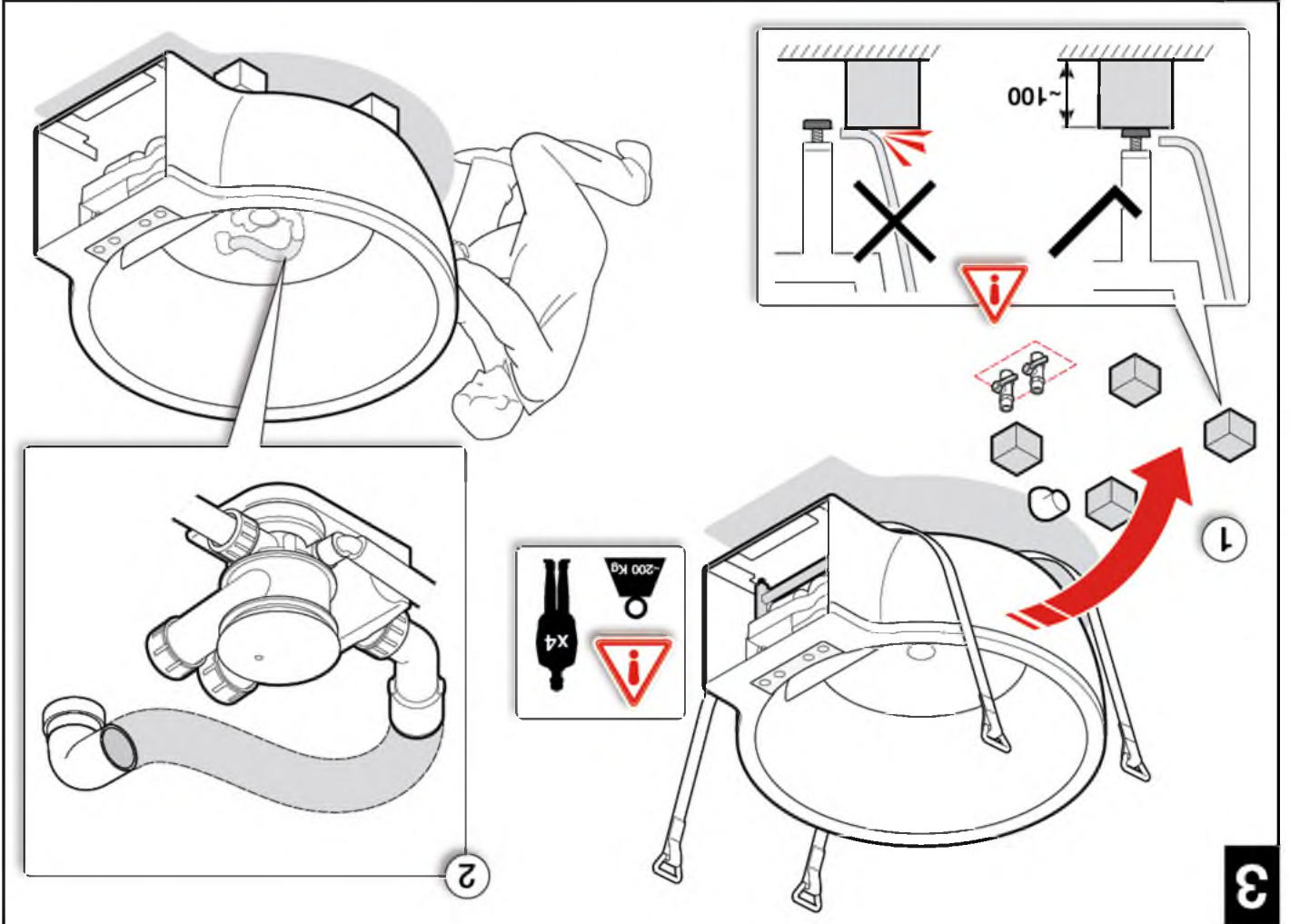
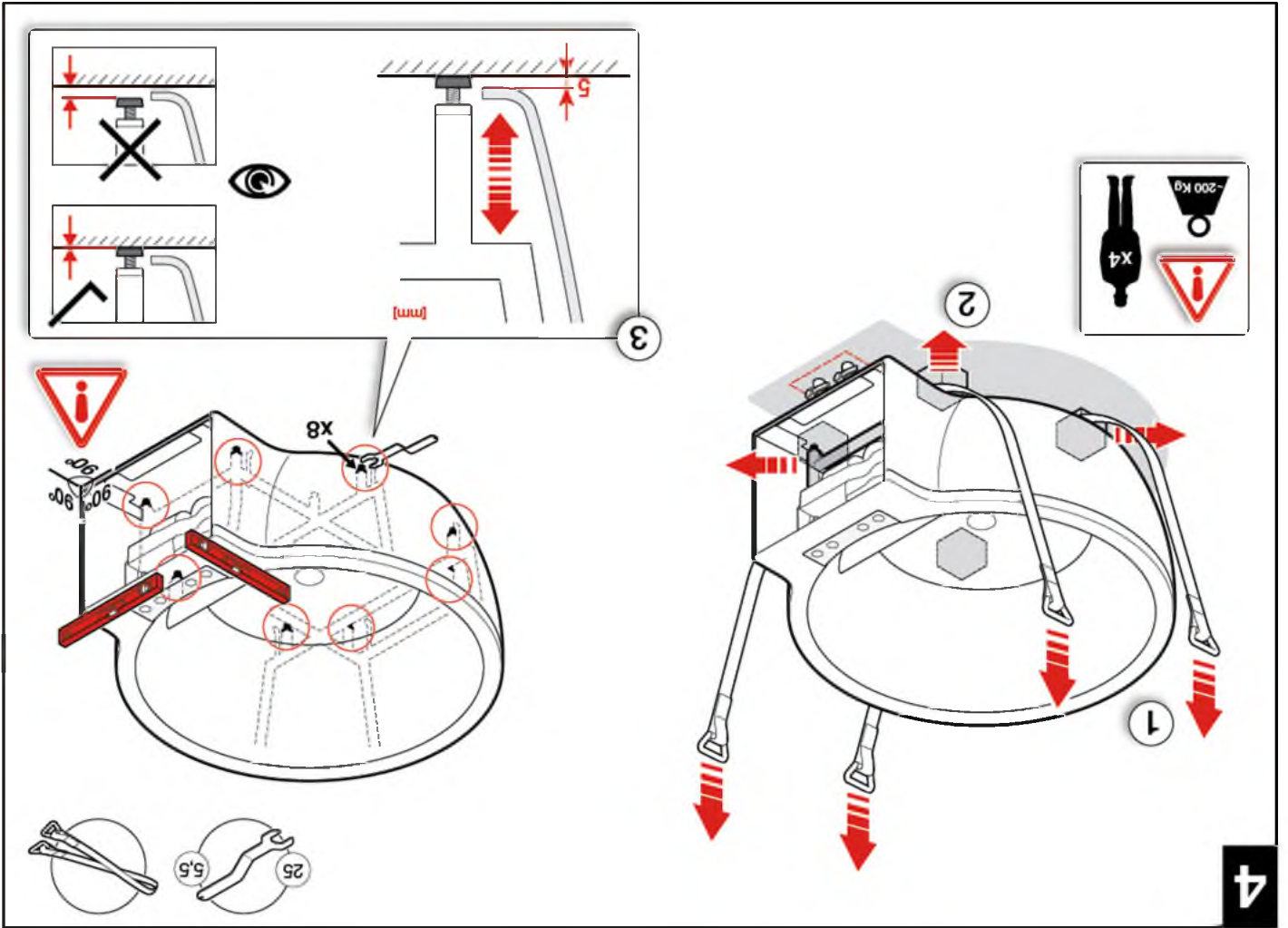

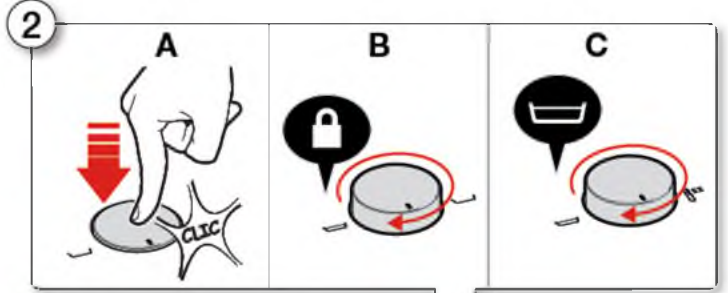
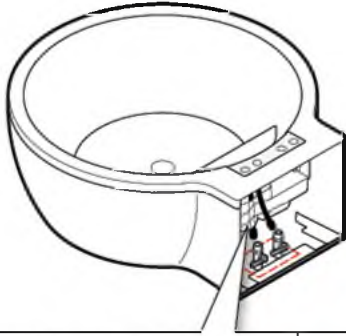
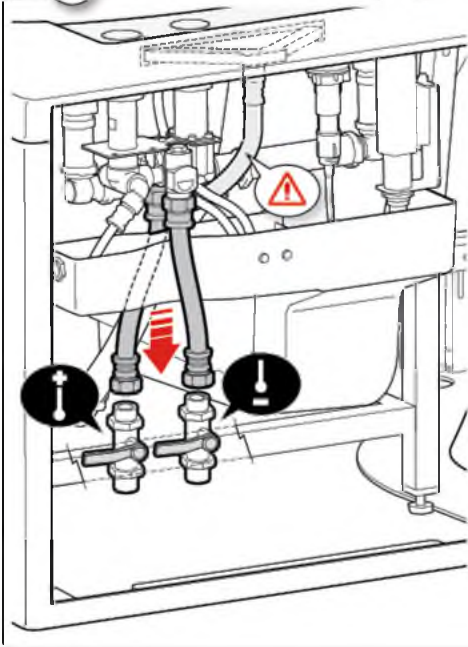
5**1**

Instalar el dispositivo de protección contra reflujo, dependiendo de la normativa local vigente. Para cumplir con la norma EN-1717, instalar la referencia Roca: A248312000

Install the backflow preventer device, depending on current local regulations. In order to comply with EN-1717, install Roca reference: A248312000

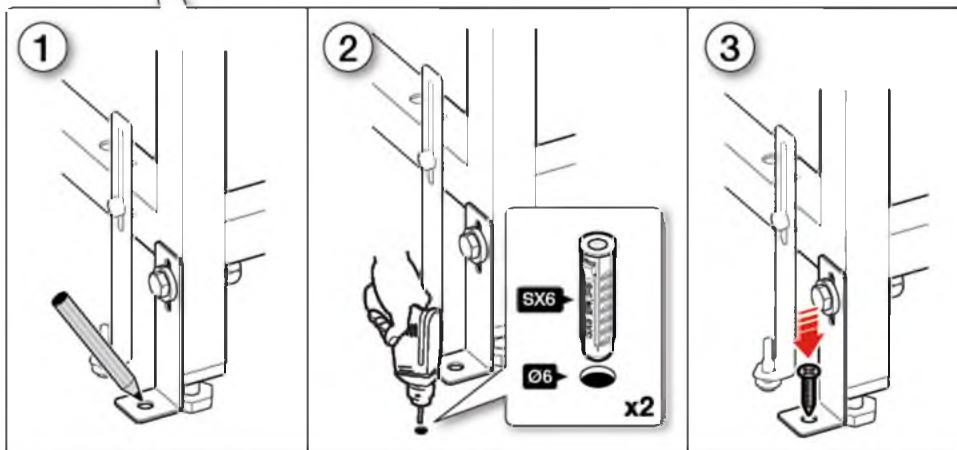
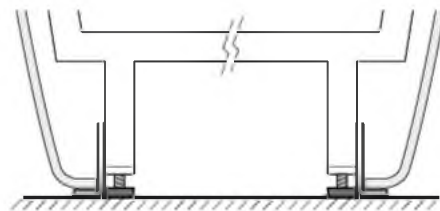
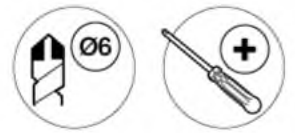
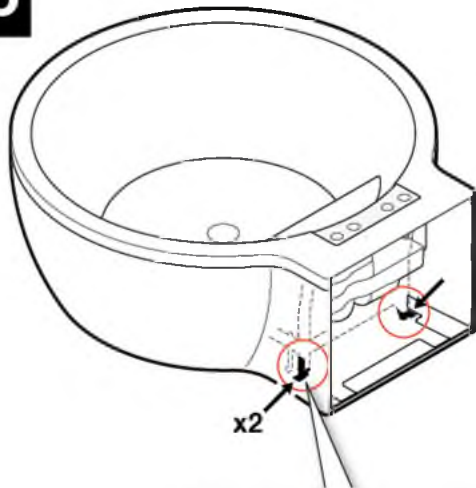
**6**

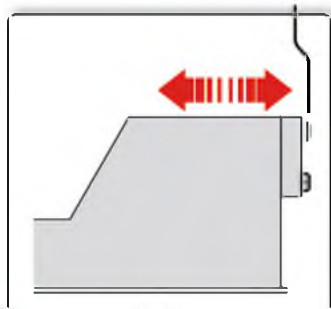
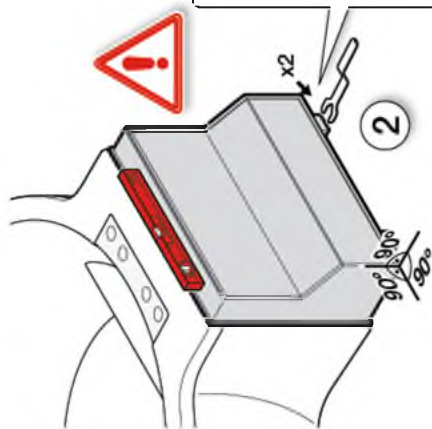
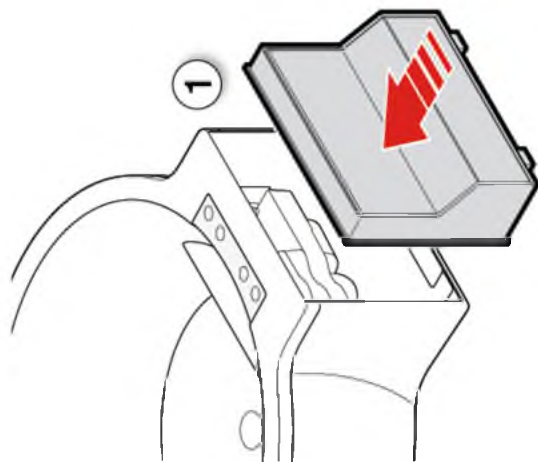

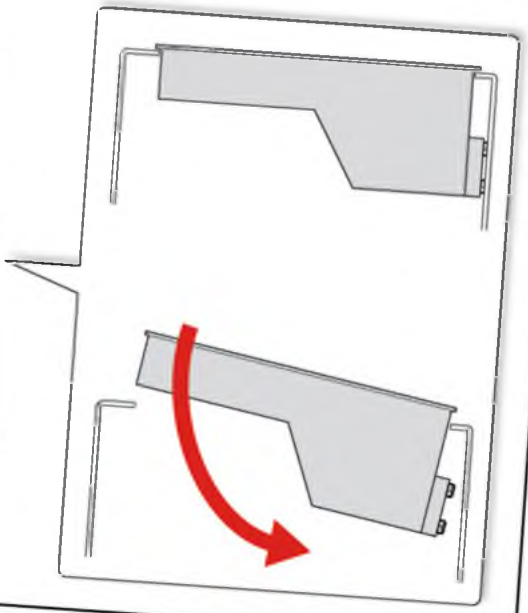
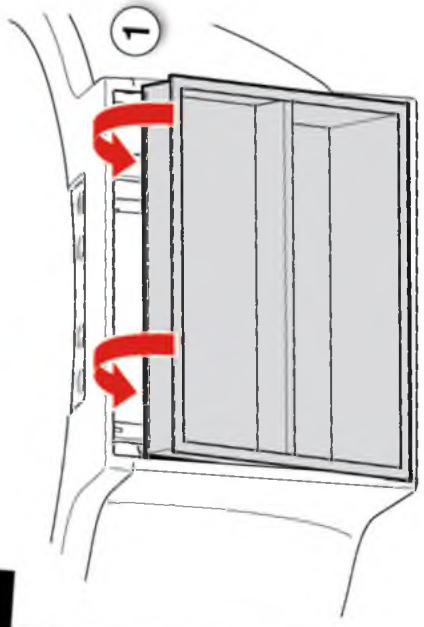
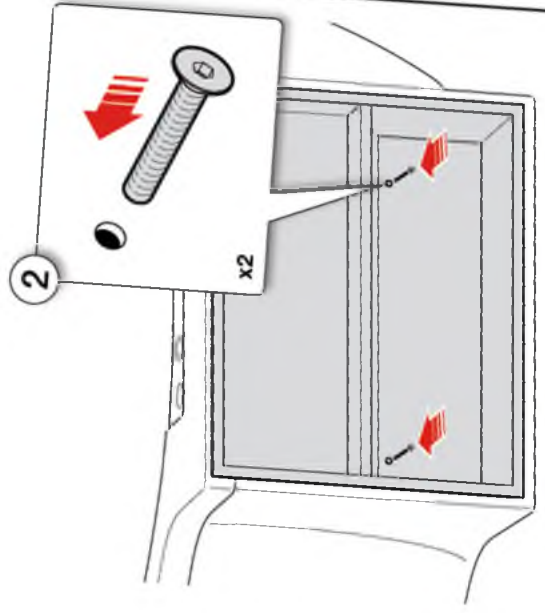



1

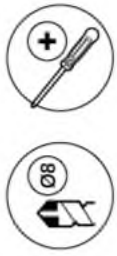
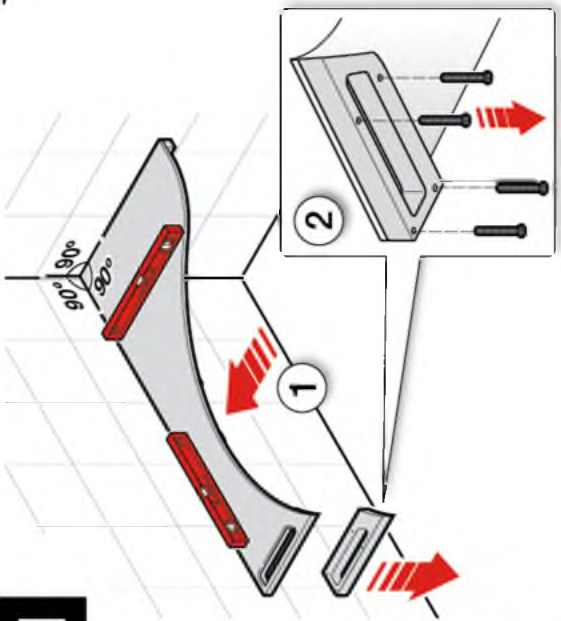

3

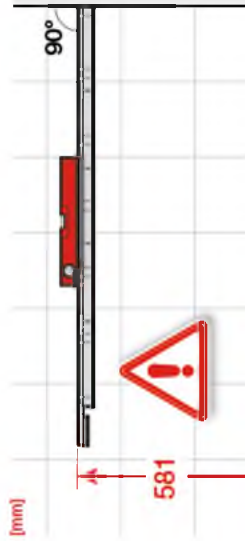
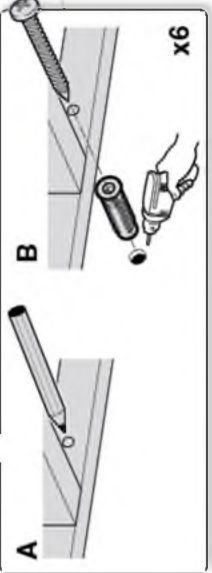
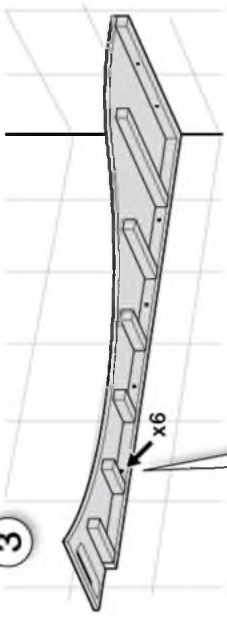

2

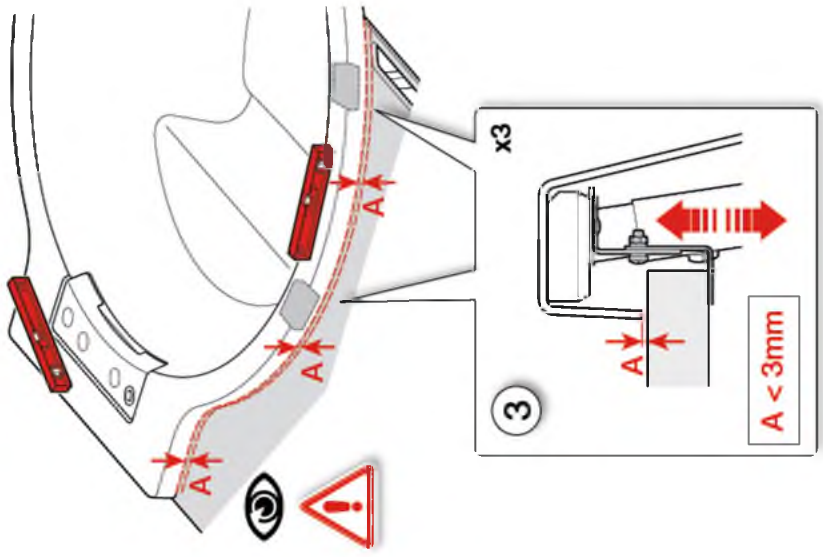
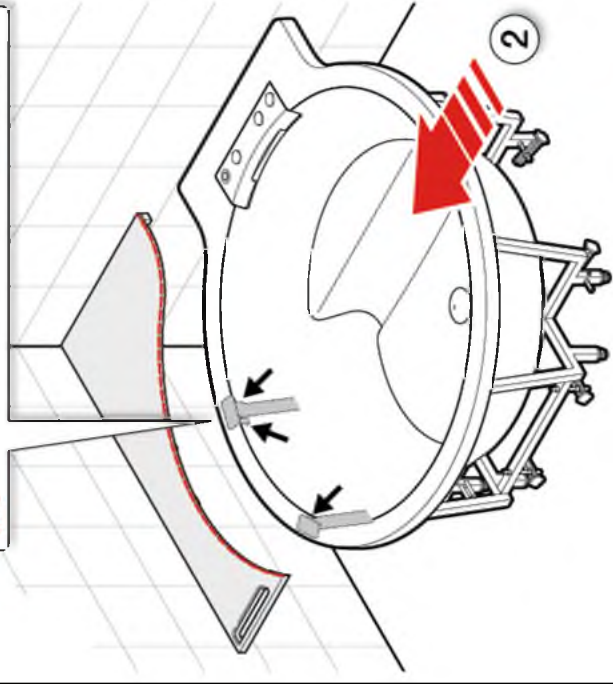
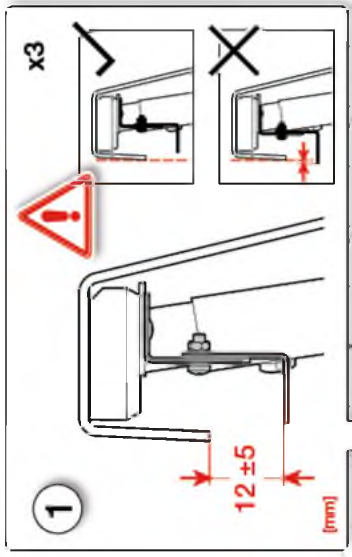

3

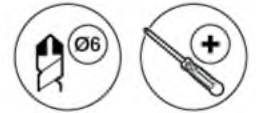

2

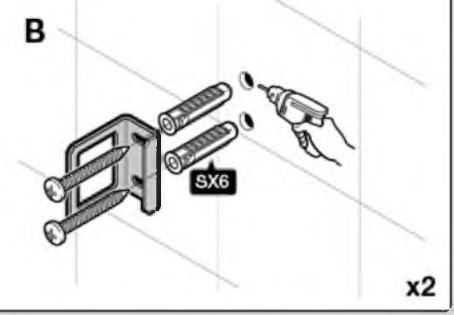
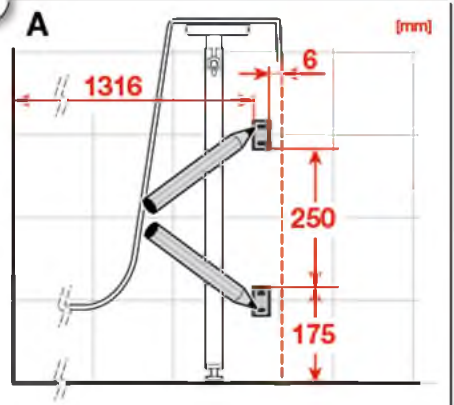

1

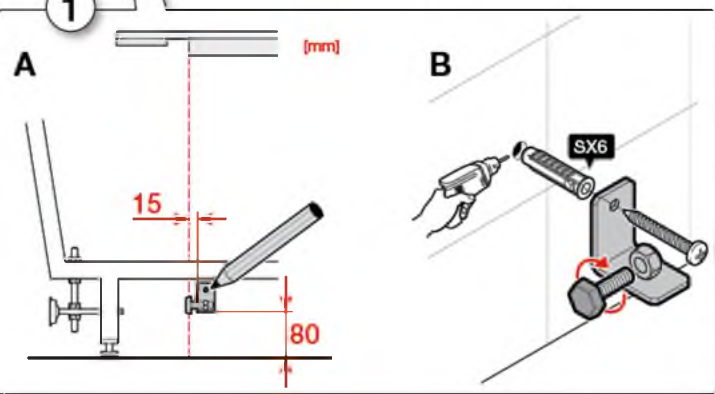

4

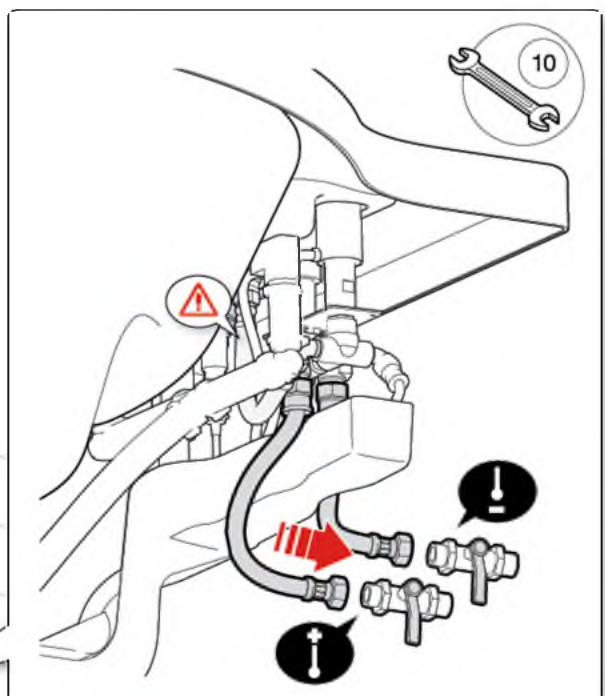
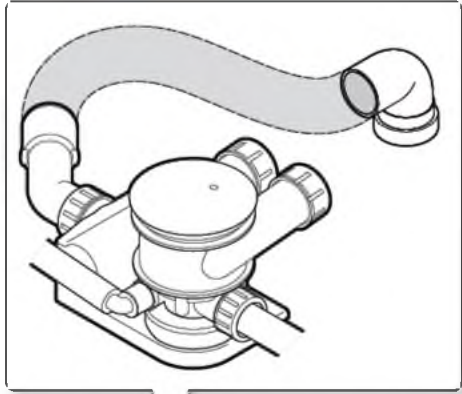

Instalar el dispositivo de protección contra reflujo, dependiendo de la normativa local vigente. Para cumplir con la norma EN-1717, instalar la referencia Roca: A248312000

Install the backflow preventer device, depending on current local regulations. In order to comply with EN-1717, install Roca reference: A248312000

5

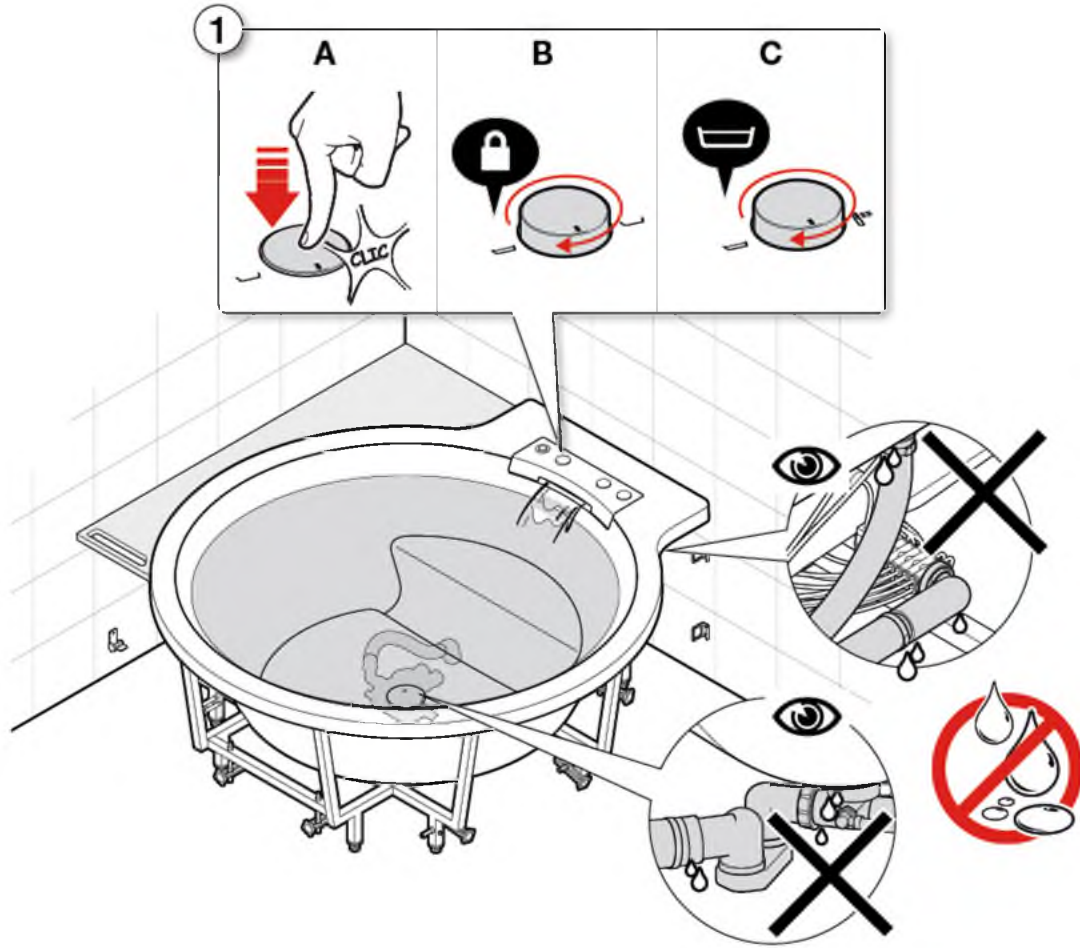

6

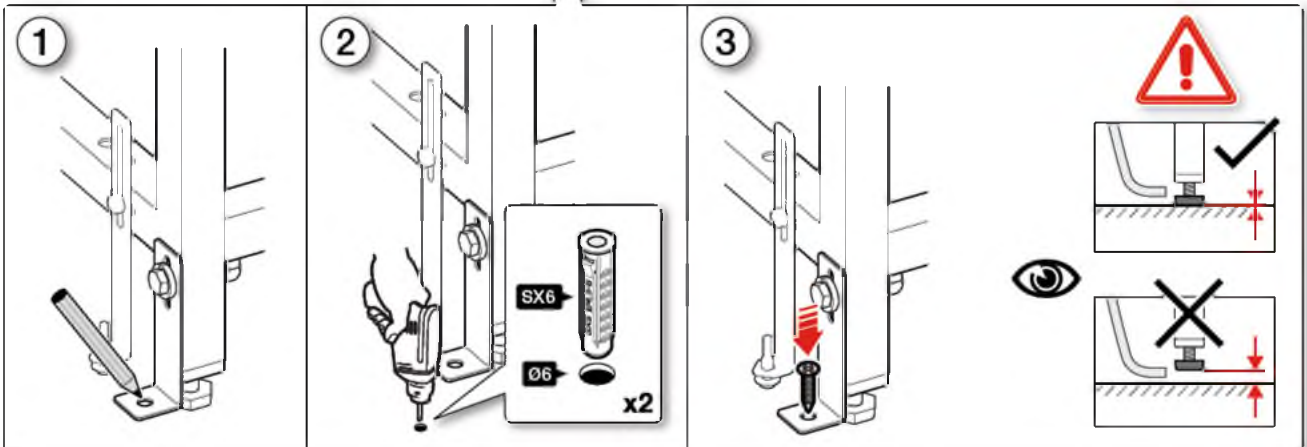
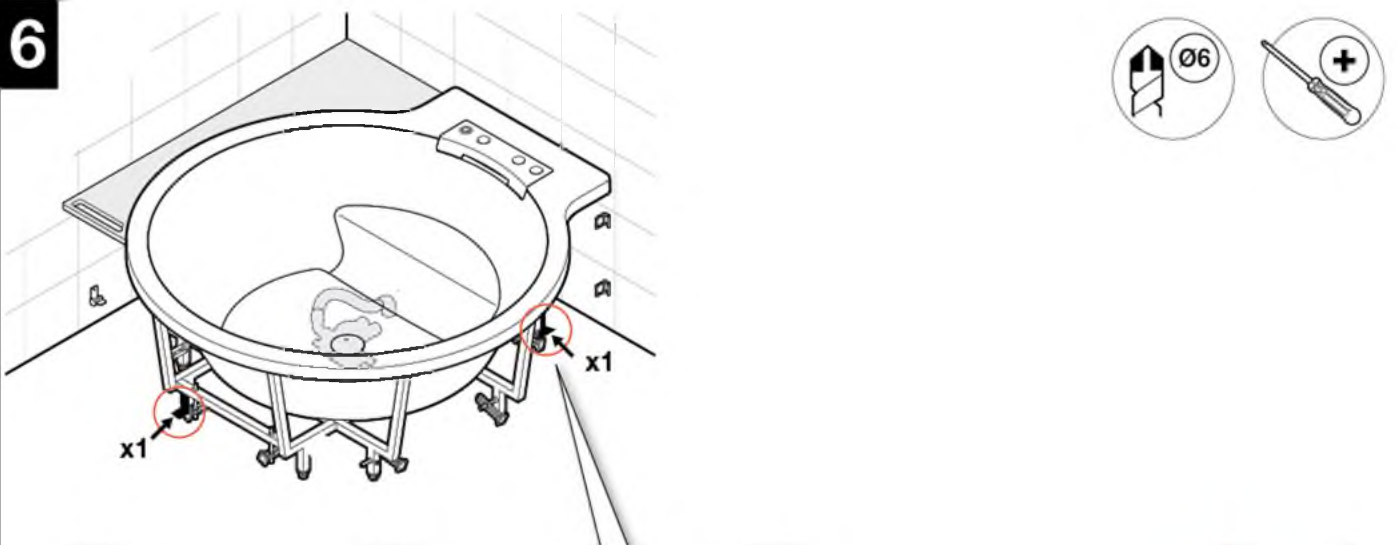

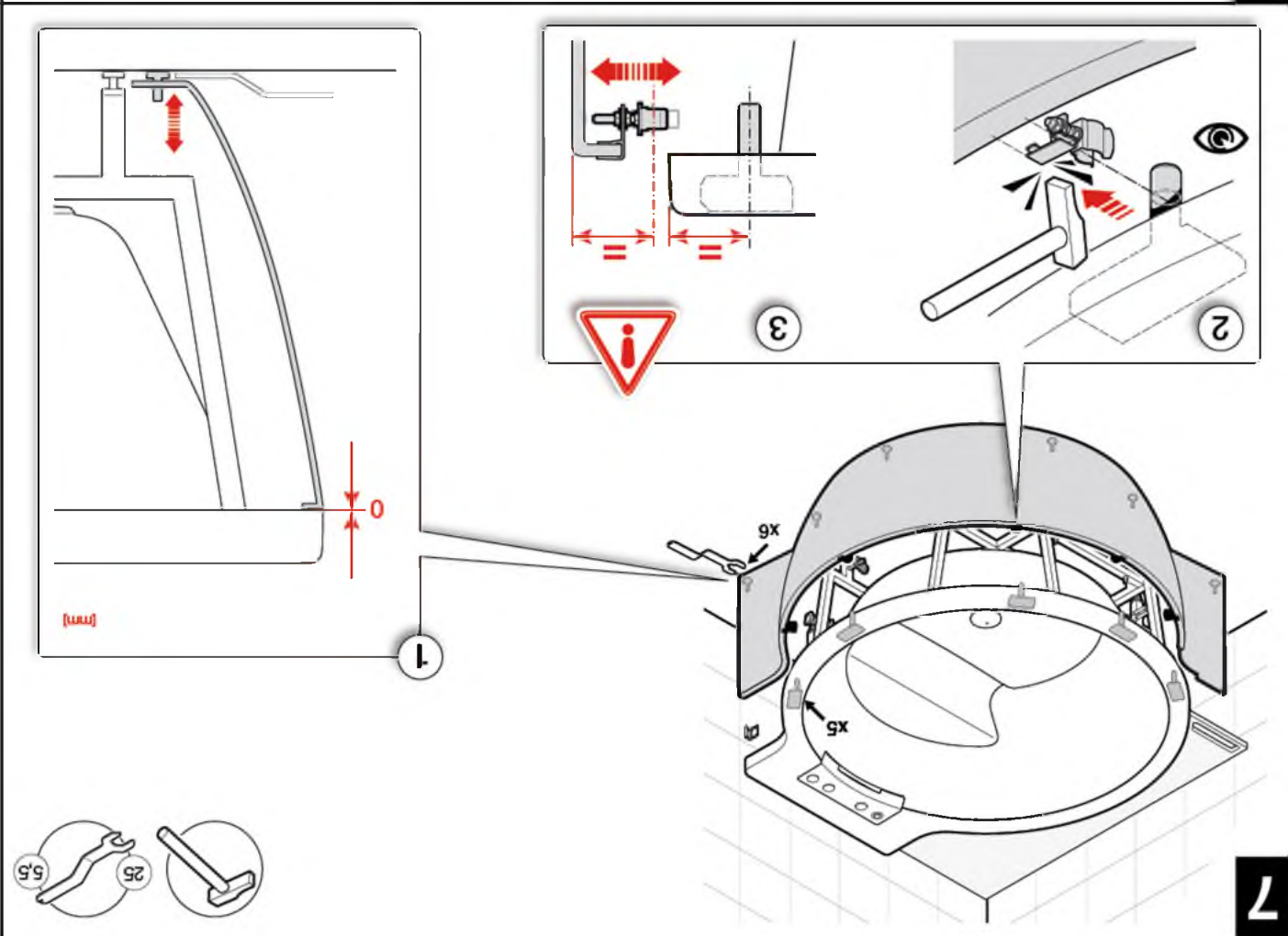
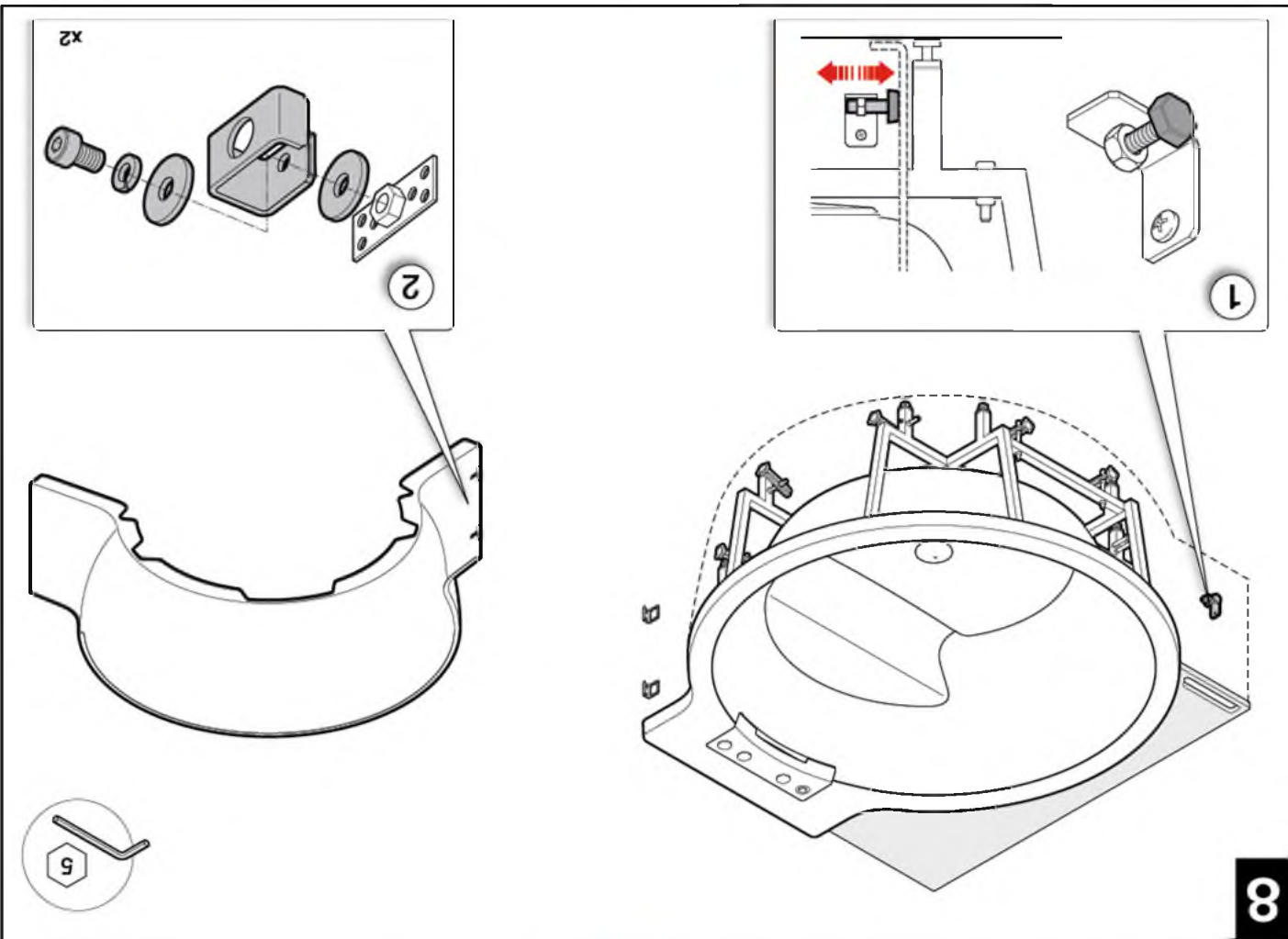

10

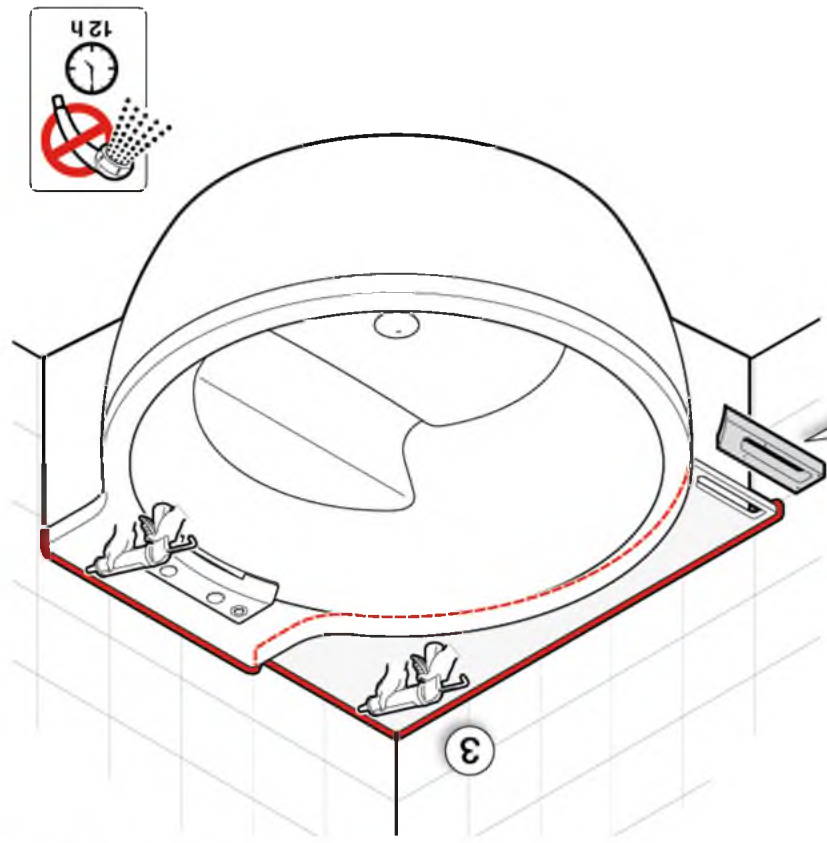
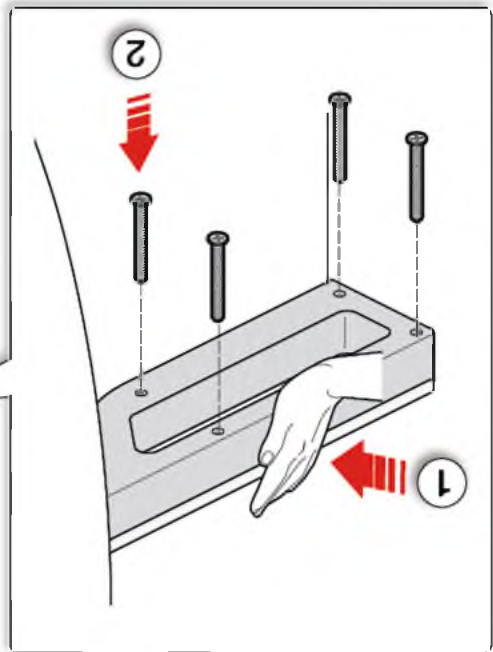

9

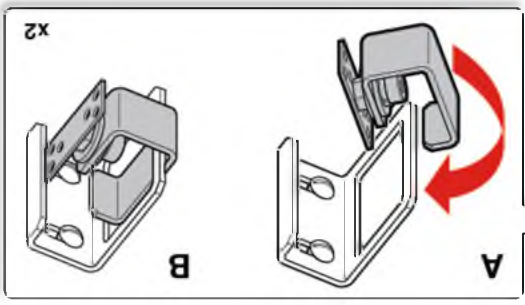
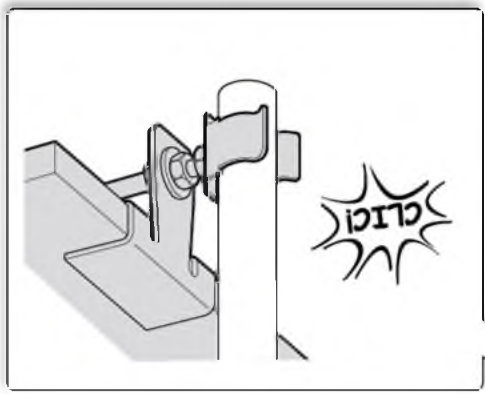
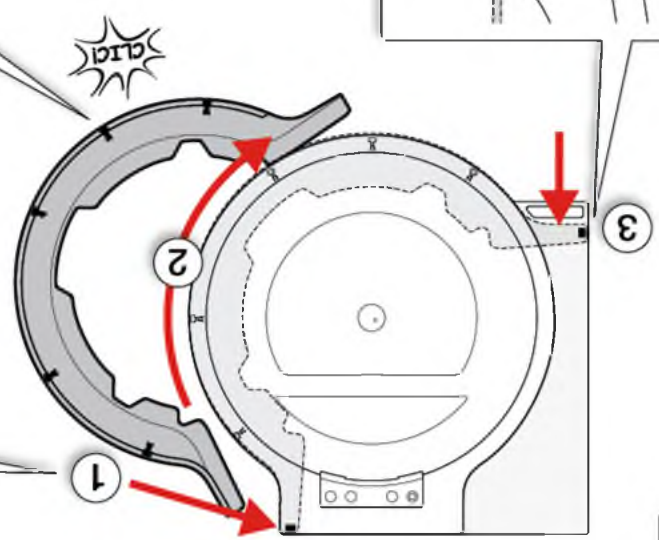
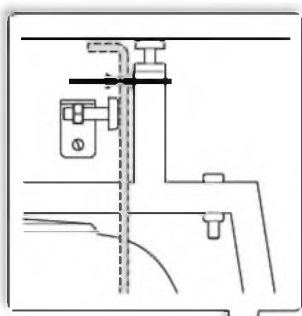

x2



1

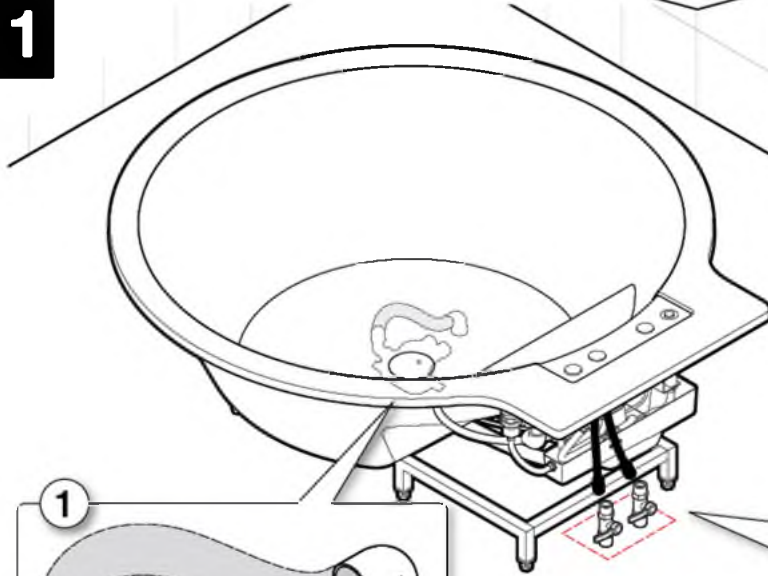

2

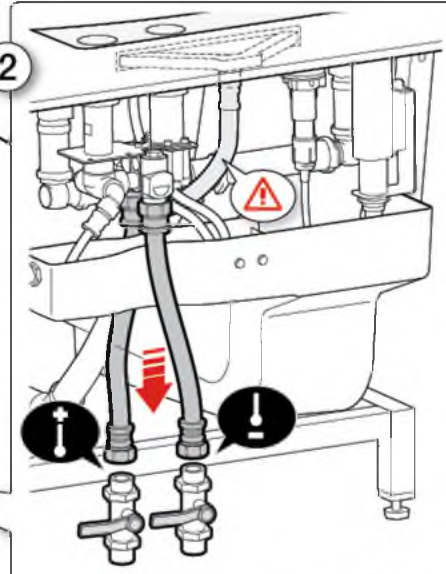

Instalar el dispositivo de protección contra reflujo, dependiendo de la normativa local vigente. Para cumplir con la norma EN-1717, instalar la referencia Roca: A248312000



Install the backflow preventer device, depending on current local regulations. In order to comply with EN-1717, install Roca reference: A248312000

1

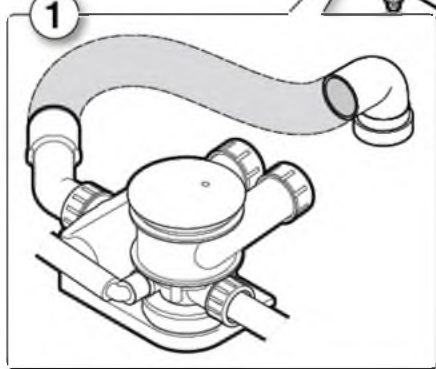

2

1

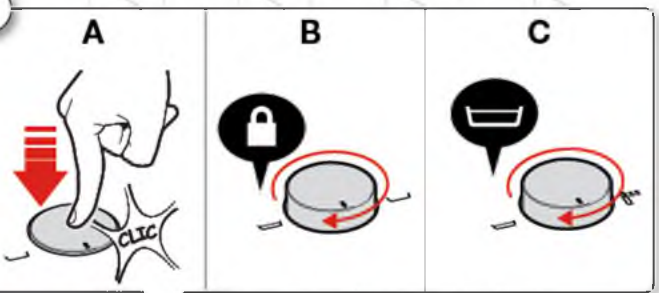

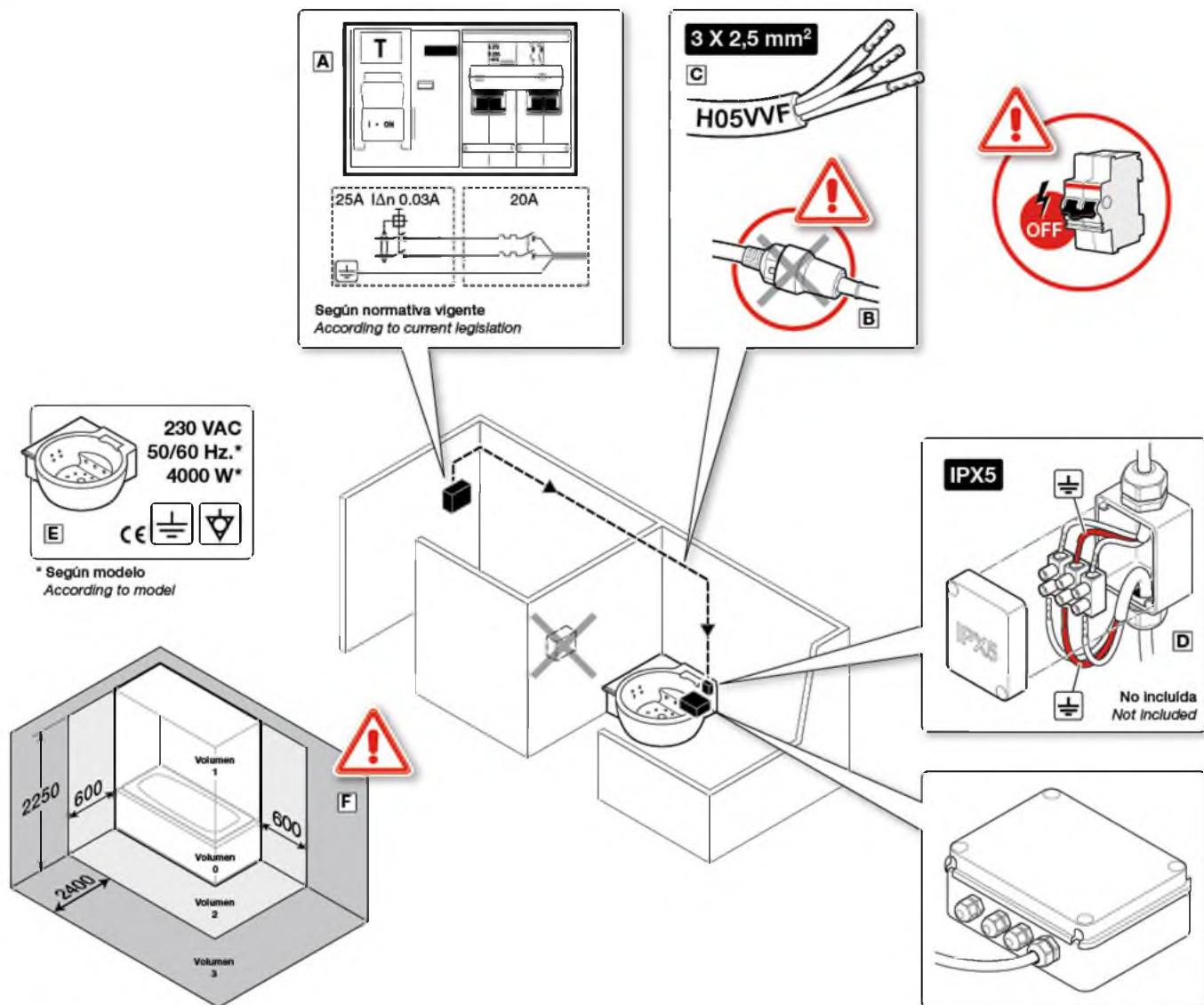

ES

A La instalación eléctrica debe protegerse mediante un interruptor diferencial de $I\Delta n$ 0,03A y 25A de potencia y de un interruptor magnetotérmico de 20A, situado fuera de los volúmenes del cuarto de baño.

B La conexión de la alimentación de este producto debe realizarse directamente a una instalación fija. No es aceptable la colocación de un enchufe.

C La línea eléctrica a instalar debe de ser de tres conductores (fase, neutro, tierra) de 2,5mm² de sección exclusivamente dedicada a la bañera. En caso de que por avería fuese necesaria la manipulación o sustitución del cable de alimentación, únicamente podrá ser realizado por el Servicio Técnico.

D La conexión a la alimentación debe realizarse en el interior de una caja eléctrica que presente un grado de protección mínimo IPX5. También debe usarse una caja de este tipo en caso de haberse de realizar un empalme de la línea de alimentación.

E La bañera debe conectarse a 230V, 50/60Hz (según modelo), a una buena toma de tierra y al borne equipotencial.

F La bañera debe de instalarse teniendo en cuenta los volúmenes de protección de forma que no haya ningún aparato eléctrico ni ninguna toma de corriente a menos de 600mm de la bañera, evitando así que una persona, dentro de la bañera, pueda llegar a tocarlo.

No se debe manipular ningún componente o conexión de la bañera.

No se debe introducir ningún aparato eléctrico dentro la bañera.

La instalación debe ser efectuada por personal cualificado, de acuerdo a la normativa nacional vigente.

EN

A The electrical installation must be protected by means of a $I\Delta n$ 0,03A and 25A differential switch and a magnetothermal switch of 20A. Both switches must be placed outside the bathroom.

B The power connection of this product must be permanently connected to a fixed electricity line. Placement of a plug is not acceptable.

C The electrical line to be installed must consist on three drivers (phase, neutral, earth) of 2,5mm² of section exclusively dedicated to the bathtub. In the event that, due to failure, it is necessary to handle or replace the power cable, this must only be done by Technical Service staff.

D The power connection must only be done inside an electrical box with a minimal degree of protection IPX5. In case of making a junction of the electrical line must be also used a box of this type.

E The bathtub should be connected to a 230V, 50/60Hz (depending on model), supply with a good earth connection and equipotential terminal.

F The bathtub must be installed in according to the protection volumes in mind so that there is neither any electrical device nor any socket to less of 600mm of the bathtub, avoiding so a person, inside the bathtub, could manage to touch it.

Neither component nor connection of the bathtub must be operated.

No electrical device must be introduced inside the bathtub.

This product must be installed by qualified personnel, in according with the national current regulation.

4

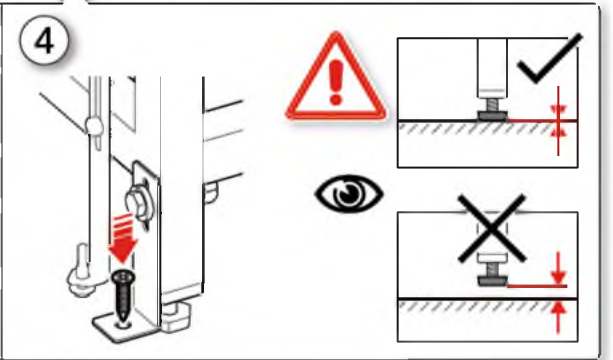
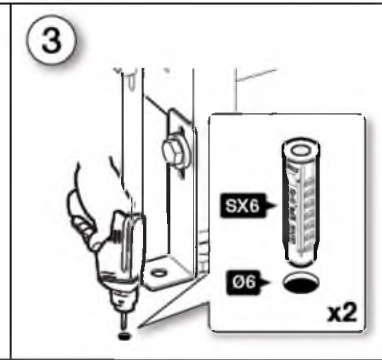
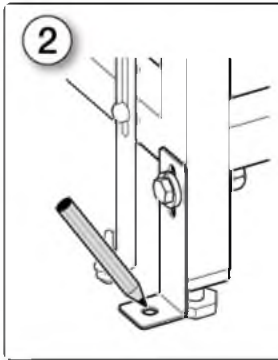
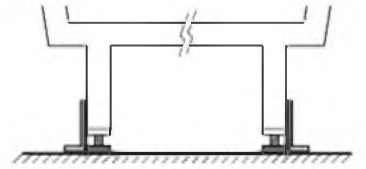
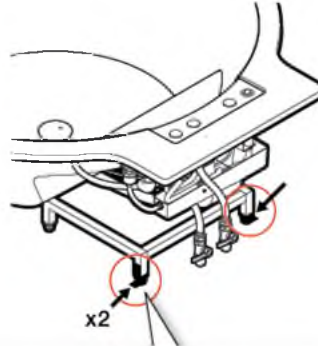
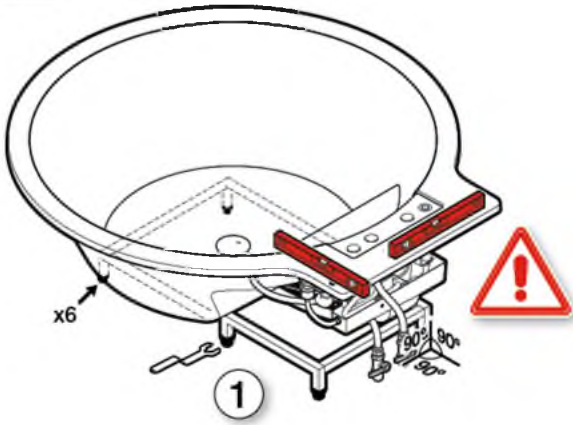
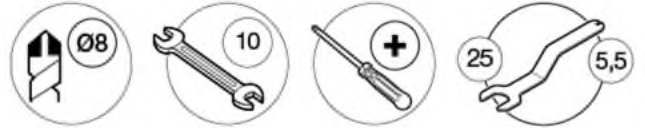

5

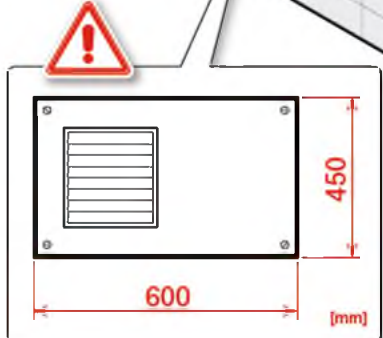
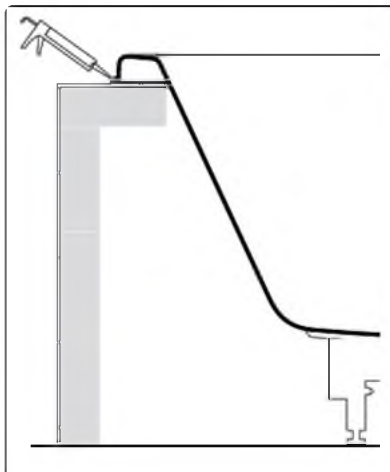
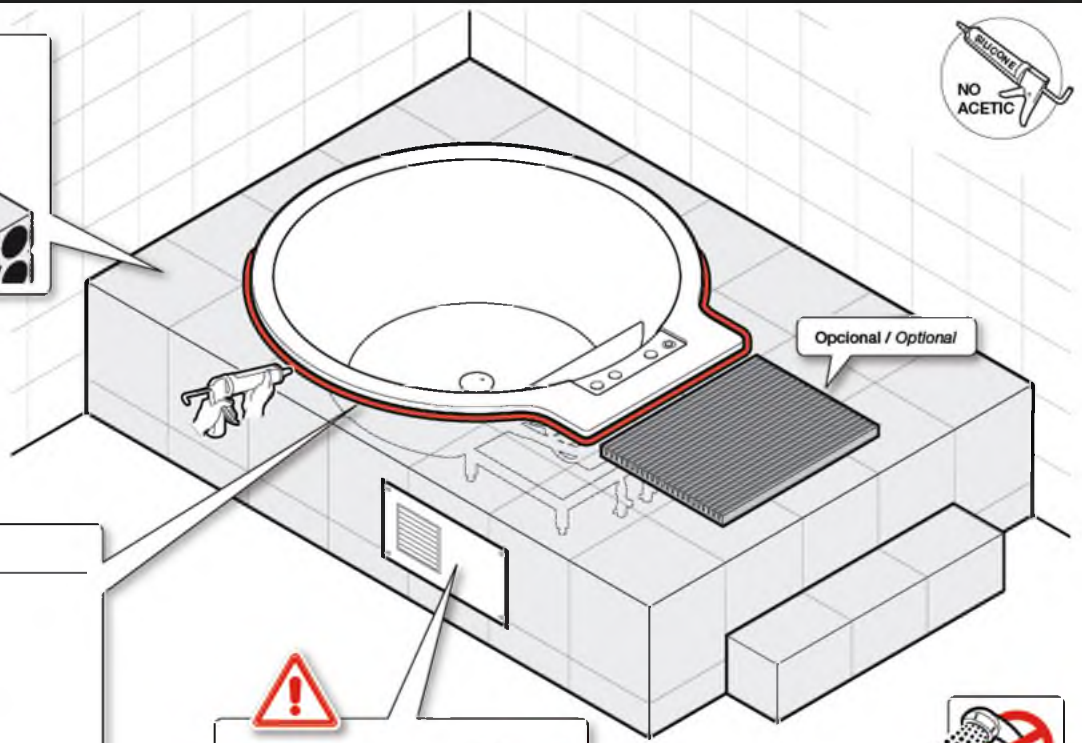
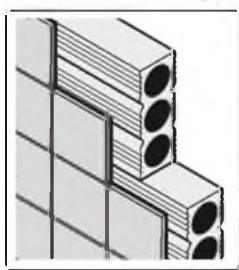



Selector salida agua Water outlet selector

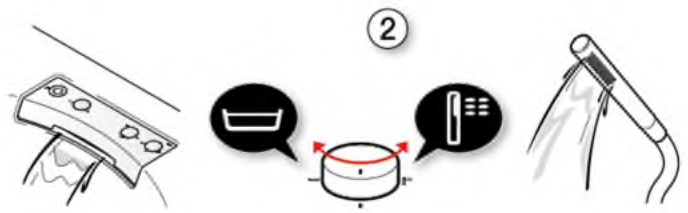

Grifería Termostática Thermostatic knob

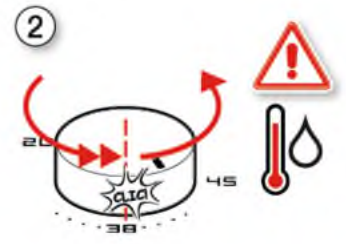
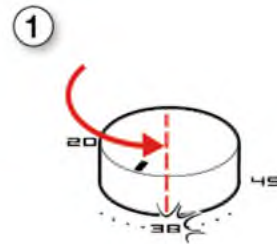

Mando desagüe Drain control

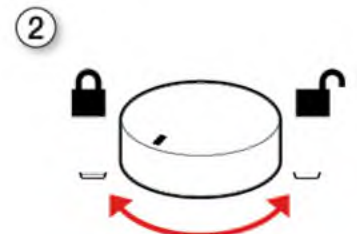

Ducha de mano Hand shower

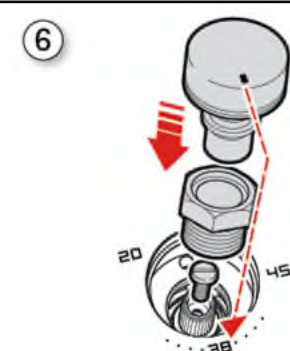
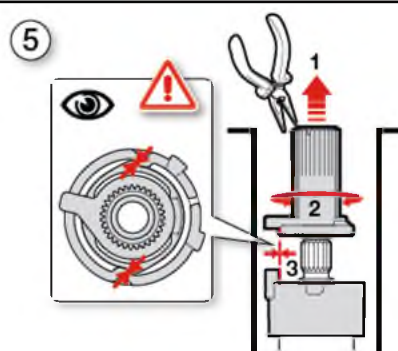
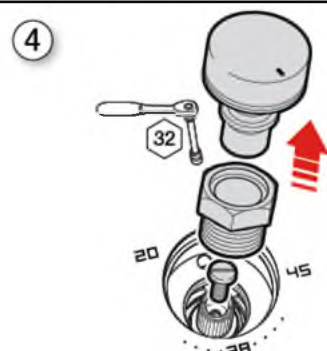
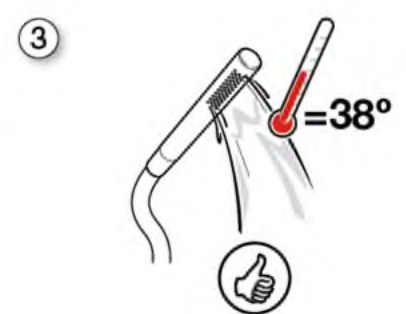
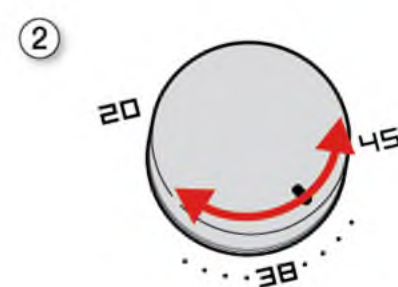





Roca Sanitario, S.A.
Avda. Diagonal, 513
08029 Barcelona
SPAIN
www.roca.com

**902
304
848** 
LÍNEA DE
ATENCIÓN AL
CONSUMIDOR
ESPAÑA

**902
400
423** 
SERVICIO
TÉCNICO
ESPAÑA

productsupport.rs@roca.net
soporteproducto.rs@roca.net