



Roca

IN-TANK

A893301000

A893302000

A893303000

ES / EN / DE / FR / IT / PT

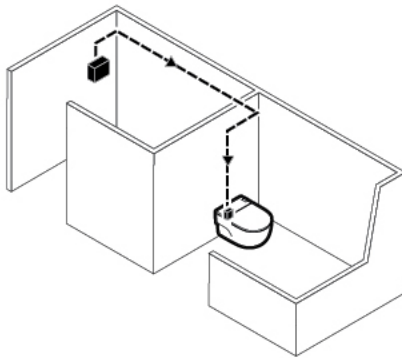

- ES** Antes de realizar cualquier operación de mantenimiento, cortar la alimentación eléctrica del inodoro.
- EN** Before any maintenance operation, shut off the toilet power supply line.
- DE** Vor jeglichen Wartungsarbeiten die Stromversorgung des WCs abschalten.
- FR** Avant de réaliser toute opération de maintenance, couper toute alimentation électrique.
- IT** Prima di effettuare qualsiasi operazione di manutenzione, spegnere linea di alimentazione in bagno.
- PT** Antes de realizar qualquer operação de manutenção, desligue a sanita da corrente elétrica.



5 min

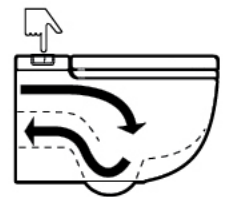

- ES** Cuando el inodoro ha estado desconectado por mucho tiempo o es el primer uso, se necesitan 5 minutos antes de su utilización.
- EN** When WC has been unplugged for a long time or if it's the first use, 5 minutes are needed to start operation.
- DE** Falls das WC lange Zeit nicht an die Stromversorgung angeschlossen war oder zum ersten Mal benutzt wird, vor der Nutzung 5 Minuten warten.
- FR** Quand le WC a été connecté pendant un long temps ou qu'il s'agit de la première utilisation, il est nécessaire d'attendre 5min avant son utilisation.
- IT** Se il vaso è stato scollegato per un lungo periodo o se è il primo utilizzo, sono necessari almeno cinque minuti per avviare il funzionamento.
- PT** Quando a sanita fica desligada por um longo período de tempo ou se é a primeira utilização, são necessários 5 minutos para iniciar o normal funcionamento.

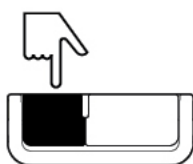
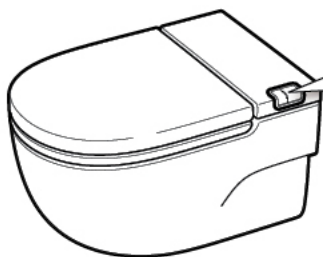

3L

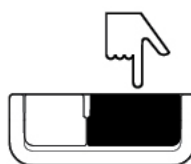

4.5L

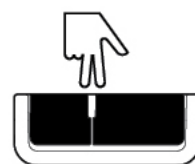

2L



ES 3 volúmenes de descarga:

- 1/2 descarga
- descarga completa
- descarga nocturna

FR 3 volumes de chasse:

- 1/2 3 volumes de chasse:
- chasse complète
- chasse nocturne

EN 3 flush volumes:

- 1/2 flush
- full flush
- night flush

IT 3 opzioni di scarico:

- mezzo scarico
- scarico completo
- scarico notturno

DE 3 Spülvolumen:

- 1/2 Spülung
- vollständige Spülung
- nächtliche Spülung

PT 3 volumes de descarga:

- 1/2 descarga
- descarga completa
- descarga noturna

ES Opción de instalación izquierda o derecha de los botones

EN Optional installation for left or right hand buttons

DE Optionale Installation der Tasten links oder rechts

FR Le bouton de chasse peut être installé à gauche ou à droite

IT Installazione opzionale per i pulsanti a sinistra o a destra

PT Instalação opcional dos botões no lado esquerdo ou no lado direito

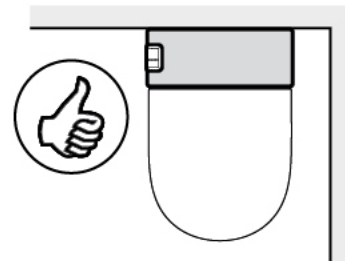
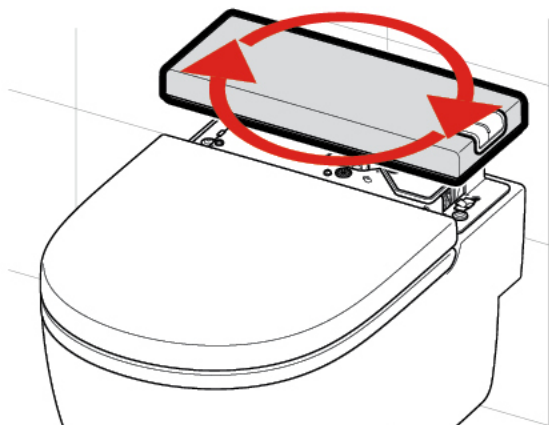
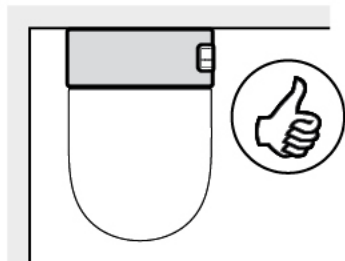

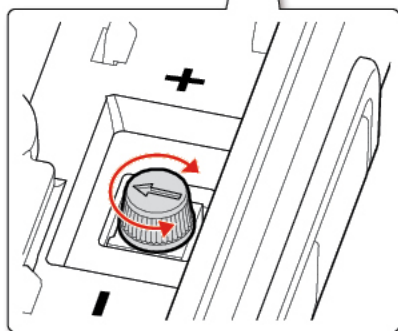
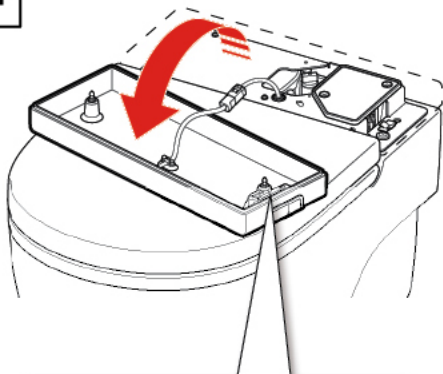

- ES Ajuste de volumen de descargas
- EN Flush volume adjustment
- DE Einstellung des Spülvolumens
- FR Ajustement du volume de chasse d'eau
- IT Regolazione del volume di scarico
- PT Ajuste do volume de descargas

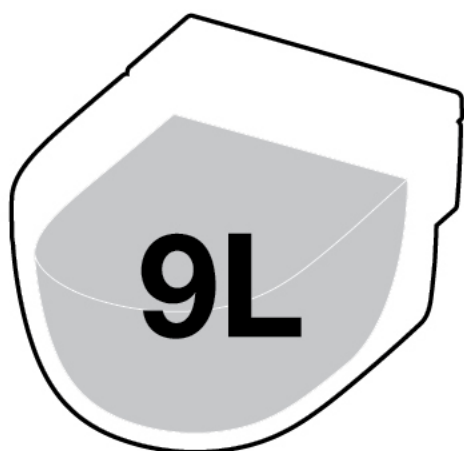
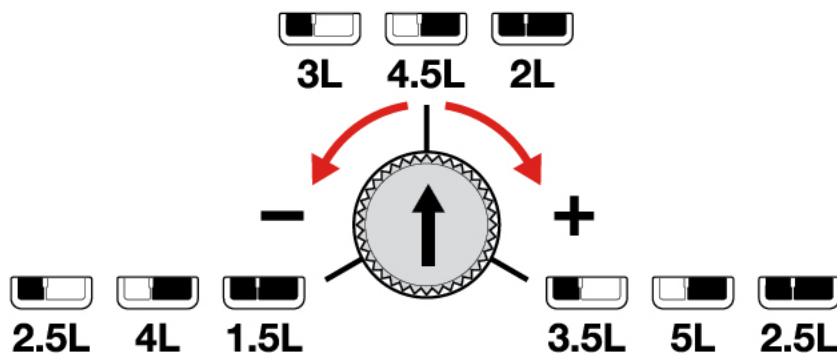

- ES **Capacidad del depósito**
El depósito de agua tiene una capacidad de 9 litros, lo que permite realizar 3 descargas consecutivas de 3L ó 2 descargas de 4.5L.
- EN **Tank capacity**
The water tank has 9 liters capacity, it allows to flush the toilet 3 times with 3L or 2 times with 4.5L.
- DE **Fassungsvermögen des Spülkastens**
Der Spülkasten hat ein Fassungsvermögen von 9 Litern, d.h. es können 3 aufeinanderfolgende Spülungen von 3 L oder 2 Spülungen von 4,5 L durchgeführt werden.
- FR **Capacité du réservoir**
Le réservoir a une capacité de 9 litres, ce qui permet de réaliser 3 chasses de 3L consécutives ou bien 2 chasses de 4.5L.
- IT **Capacità del vaso**
Il serbatoio dell'acqua ha una capacità di 9 litri e permette di tirare l'acqua 3 volte con 3L o 2 volte con 4.5L.
- PT **Capacidade do depósito**
O depósito de água tem capacidade para 9 litros, o que permite 3 descargas consecutivas de 3L ou 2 descargas de 4,5L.

**ES Señal luminosa**

Después de efectuar 1 o más descargas, la luz parpadea de forma suave mientras se está ejecutando el llenado del depósito.

EN Light signal

After 1 or more flushes, the light blinks softly while water tank is filling.

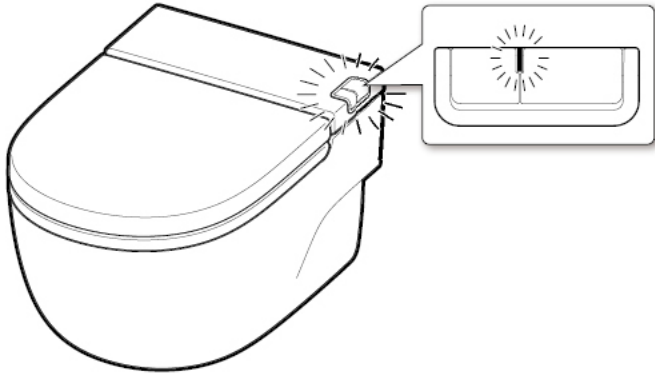
**DE Lichtsignal**

Nach 1 oder mehrerer Spülungen blinkt das Licht leicht während der Füllung des Spülkastens.

FR Signal lumineux

Avant d'effectuer une chasse ou plus, la lumière du bouton de chasse clignote légèrement pour indiquer que le réservoir se remplit

IT Segnale luminoso

Dopo uno o più flussi, mentre il serbatoio dell'acqua si sta riempiendo, la spia lampeggia debolmente.

PT Sinal luminoso

Dopo uno o più flussi, mentre il serbatoio dell'acqua si sta riempiendo, a luz pisca rapidamente.



	1	2	3	4	5	6	7	8	9	10	11	12
3L	Dark	Dark	Dark	Dark	Dark	Dark	Dark	Dark	Dark	Dark	Dark	Dark
4.5L	Dark	Dark	Dark	Dark	Dark	Dark	Dark	Dark	Dark	Dark	Dark	Dark
2L	Dark	Dark	Dark	Dark	Dark	Dark	Dark	Dark	Dark	Dark	Dark	Dark

DE Fallo del suministro eléctrico

- En caso de fallo de suministro eléctrico, el inodoro permite realizar un número de descargas (ver tabla).
- Cuando no hay suficiente energía en el inodoro, la luz parpadea rápidamente.

EN Power supply failure

- In case of power supply failure, the toilet keeps operative for a number of flushes (tee table).
- When there is not enough power in the toilet, the light flashes at a high frequency.

DE Ausfall der Stromversorgung

- Im Falle eines Stromausfalls können eine bestimmte Anzahl an Spülungen vorgenommen werden (siehe Tabelle).
- Wenn das WC über zu wenig Strom verfügt, blinkt das Licht schnell.

FR Coupure d'électricité

- En cas de coupure d'électricité, le WC peut encore effectuer un certain nombre de chasses (cf tableau).
- Quand il n'y a plus suffisamment d'électricité, la lumière clignote rapidement.

IT Assenza di alimentazione

- In caso di mancanza di alimentazione, il vaso si mantiene operativo per un certo numero di scarichi (come riportato nella tabella a fianco).
- Qualora non ci fosse una potenza sufficiente in bagno, la luce lampeggia con frequenza elevata.

PT Falha de alimentação elétrica

- No caso de falha de alimentação elétrica, a sanita mantém-se operacional durante um certo número de descargas (ver tabela).
- Quando não há energia suficiente na sanita, a luz pisca rapidamente.



ES Fallo del suministro de agua

Debido a la capacidad del depósito, el inodoro permite realizar un número de descargas (dependiendo del volumen: 3L, 4.5L ó 2L), aún en ausencia de aporte de agua de la red.

EN Water supply failure

Due to its high water capacity, the toilet allows a certain number of flushes (depending on volume: 3L, 4.5L, or 6L), even in water supply failure conditions.

DE Ausfall der Wasserversorgung

Dank des Fassungsvermögens des Spülkastens können eine bestimmte Anzahl an Spülungen auch ohne Wasserversorgung vorgenommen werden (abhängig vom Spülvolumen: 3 L, 4,5 L oder 2 L).

FR Coupure d'eau

Grâce à la grande capacité de son réservoir, le WC peut encore réaliser plusieurs chasses (en fonction du volume: 3L, 4.5L, ou 6L) même en cas de coupure d'eau.

IT Mancanza di acqua

Grazie alla sua elevata capacità di acqua, il vaso permette un certo numero di scarichi (a seconda del volume: 3L, 4.5L, o 6L), anche in caso di assenza di acqua.

PT Falha no fornecimento de água

Devido à grande capacidade do depósito, a sanita permite um certo número de descargas (dependendo do volume: 3L, 4,5L ou 2L), mesmo durante falha no fornecimento de água.



5°C



45°C



ES Rango de temperatura para uso

No se recomienda su instalación fuera de este rango.

EN Temperature usage range

It is not recommended to install in places out of this range.

DE Temperaturbereich für die Nutzung

Eine Installation außerhalb dieses Bereichs wird nicht empfohlen.

FR Température d'utilisation du WC

L'installation n'est pas recommandée dans des pièces dont la température se trouve en dehors de ce champs.

IT Intervallo di temperatura di utilizzo

Non è raccomandabile l'installazione del prodotto in luoghi con temperature maggiori o superiori all'intervallo indicato.

PT Temperatura ambiente de uso recomendada

Não se recomenda a instalação em locais fora desta amplitude térmica.



50 kPa (0,5 bar) ~ **1000 kPa** (10 bar)

- ES Rango de presiones de entrada
- EN Range of inlet pressure
- DE Bereich Eingangsdruck
- FR Gamme de pression d'entrée
- IT Campo di pressione in entrata
- PT Pressão de alimentação recomendada

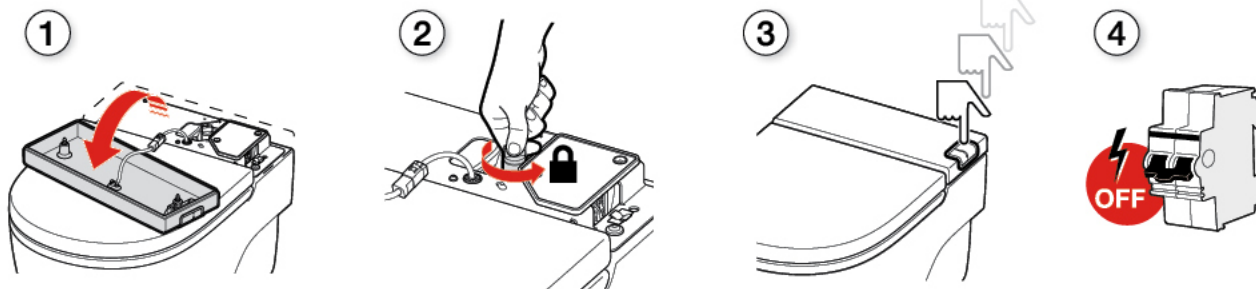

ES En caso de ausencia prolongada

En caso de un período prolongado sin utilización, especialmente en lugares muy fríos para evitar la congelación del agua en el depósito, que podría deteriorar el inodoro:

- ① Desmontar la cubierta posterior
- ② Cerrar la llave de paso
- ③ Realizar descargas hasta que no salga agua
- ④ Cortar el suministro eléctrico

EN En caso de ausencia prolongada

When not using for a long period, specially in cold places to avoid the risk of freezing of the water in the tank, which could damage the toilet:

- ① Dismount rear cover
- ② Close the stop valve
- ③ Flush until no water flushes
- ④ Shut off power supply line

DE Bei längerer Abwesenheit

Bei längerer Nichtnutzung, besonders in kalten Umgebungen, um das Gefrieren des Wassers im Spülkasten und somit eine Beschädigung des WCs zu vermeiden:

- ① Den hinteren Deckel abmontieren
- ② Das Absperrventil schließen
- ③ Spülen, bis kein Wasser mehr fließt
- ④ Die Stromversorgung abschalten

FR En cas d'absence prolongée

En cas de non utilisation durant une longue période, plus précisément des les pièces froides, afin d'éviter la congélation de l'eau dans le réservoir (ce qui pourrait endommager le WC):

- ① Démontez la partie arrière
- ② Fermez le robinet d'arrêt
- ③ Effectuez des chasses jusqu'à épuisement de l'eau dans le réservoir
- ④ Couper l'alimentation électrique

IT In caso di assenza prolungata

Nel caso in cui non si utilizzi il vaso per un lungo periodo, specialmente in luoghi freddi, per evitare il rischio di congelamento dell'acqua nel serbatoio che potrebbe danneggiare il vaso, è necessario:

- ① Rimuovere il coperchio posteriore
- ② Chiudere la valvola di arresto
- ③ Far scorrere l'acqua fino che c'è flusso
- ④ Spegnere la linea di alimentazione

PT No caso de ausência prolongada

No caso de um longo período sem utilização, especialmente em locais frios, para evitar o risco de congelamento da água no depósito, que pode danificar a sanita, deve:

- ① Desmontar a tampa
- ② Fechar a válvula de corte
- ③ Efectuar as descargas necessárias até o depósito ficar vazio
- ④ Desligar a alimentação elétrica

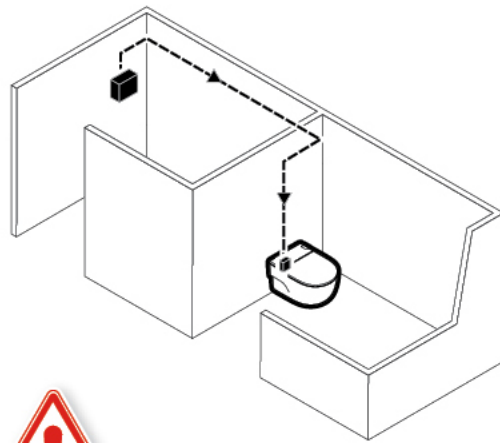

- ES** Antes de reemplazar el mecanismo, cortar la alimentación eléctrica del inodoro.
- EN** Before replacing the mechanism, shut off the toilet power supply line.
- DE** Vor dem Auswechseln des Mechanismus die Stromversorgung des WCs abschalten.
- FR** Avant de remplacer le mécanisme, coupez l'alimentation électrique du WC.
- IT** Prima di sostituire il meccanismo, spegnere la linea di alimentazione del vaso.
- PT** Antes de substituir o mecanismo, desligue o fornecimento de alimentação elétrica da sanita.

1

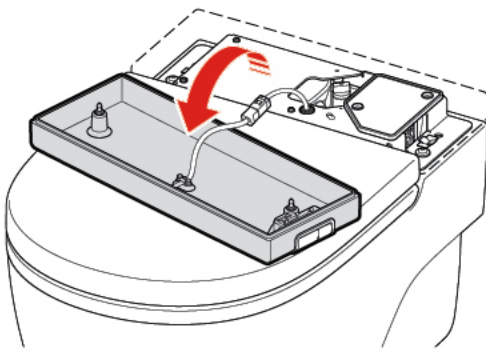

2

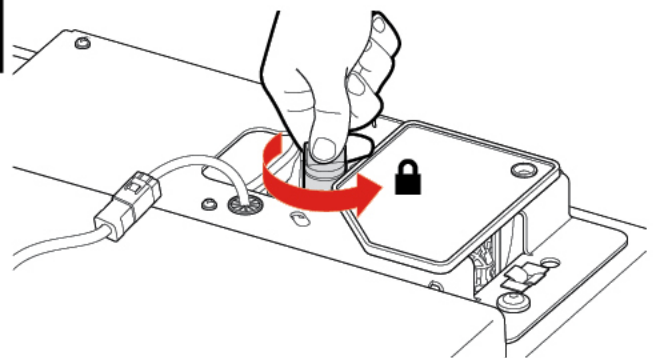

3

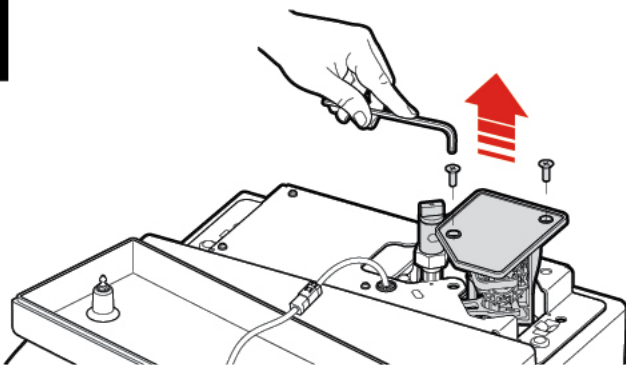

4

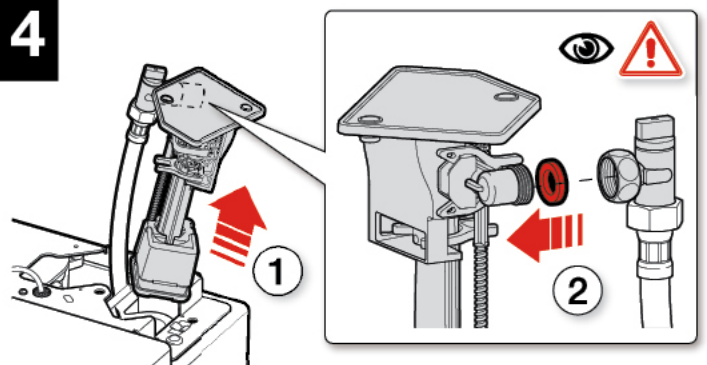

5

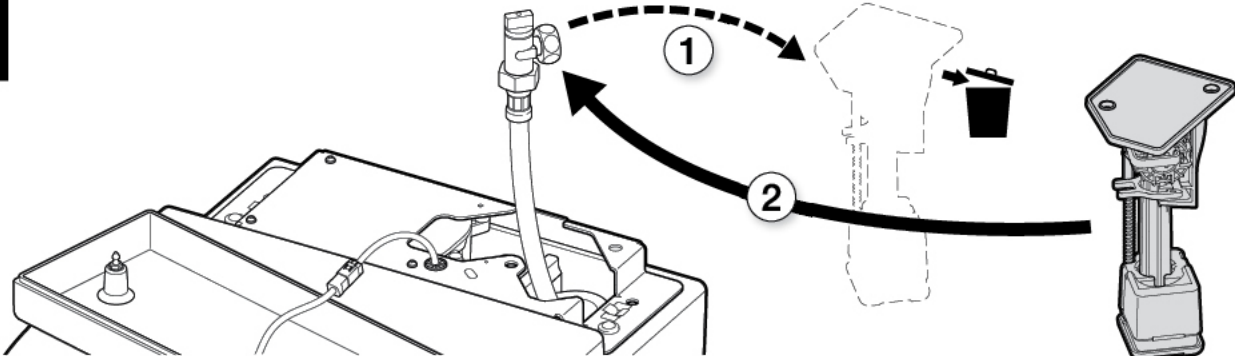

Roca Sanitario, S.A.

Avda. Diagonal, 513
08029 Barcelona
SPAIN
www.roca.com



A392501020c